

FLAT BED LATHE SERIES

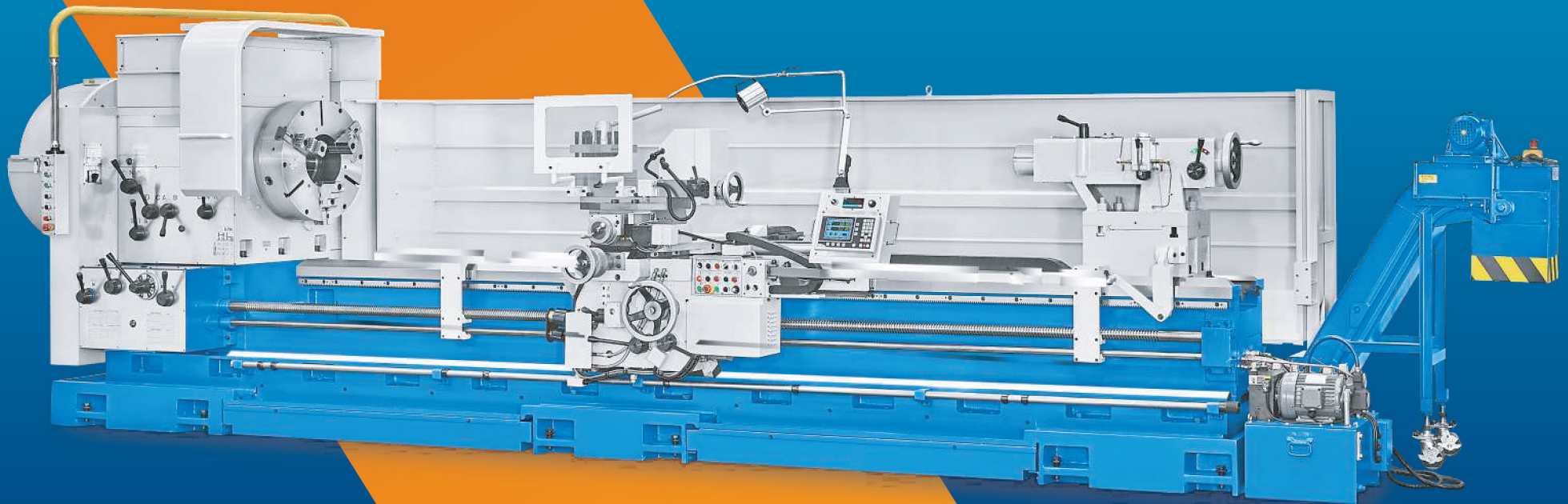

EXIMUS

FLAT BED LATHE SERIES

INTRODUCTION OF SERIES NAME			
	P / Precision	O / Oil Country	G / Multi-Guideway
M / Conventional	MPA, MPB	MOC, MOH	MGF, MGX
S / CNC	SPA, SPB	SOC, SOH, SOM	SGE, SGF, SGX

INTRODUCTION OF MODEL NAME				
MODEL NAME	MPA	XX	OOO	□
MEANING	SERIES NAME	SWING OVER BED	DISTANCE BETWEEN CENTERS <small>*per 100mm</small>	SPINDLE BORE
EXAMPLE	MPA	770	15	3

// MODEL SERIES



PRECISION SERIES



PRECISION LATHE - 16" BED
MPA600 / MPA670 / MPA770

MPA



PRECISION LATHE - 18" BED
MPB670 / MPB770 / MPB840

MPB



OIL COUNTRY SERIES



OIL COUNTRY LATHE - 22" BED
MOC960 / MOC1060 / MOC1200

MOC



HEAVY DUTY OIL COUNTRY LATHE - 32" BED
MOH1200 / MOH1400 / MOH1600

MOH



MULTI-GUIDEWAY SERIES



GIANT FOUR GUIDEWAY LATHE - 52" BED
MGF1800 / MGF2000 / MGF2250 / MGF2500

MGF



CUSTOMIZED GIANT LATHE - 72" BED
MGX2600 / MGX3100 / MGX3600

MGX

TEST REPORT

// BED REPORT

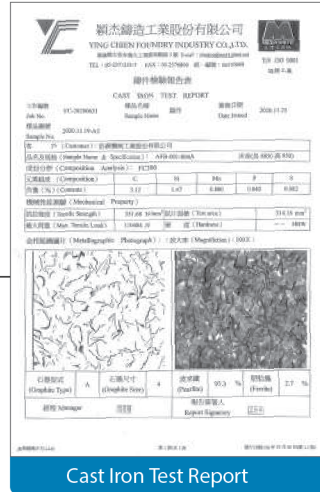

// SAFETY CERTIFICATION



BED CASTING



QUALITY CONTROL

We focus on most important aspects in guaranteeing the reliability followed by rigorous QC process in all key components. Assurance reports such as casting testing report for bed, headstock, tailstock provided by our suppliers, plus internal IQC and FQC to make sure MYDAY machines with high accuracy performance.

PRECISION LATHE - 16" BED



Heavy Duty Precision Lathe is a very popular product line in metal industry.

The spindle motor power in the series is transmitted to the spindle through pulley, belt and 12-step gear sets. It could perform heavy duty machining with high speed and high rigidity.

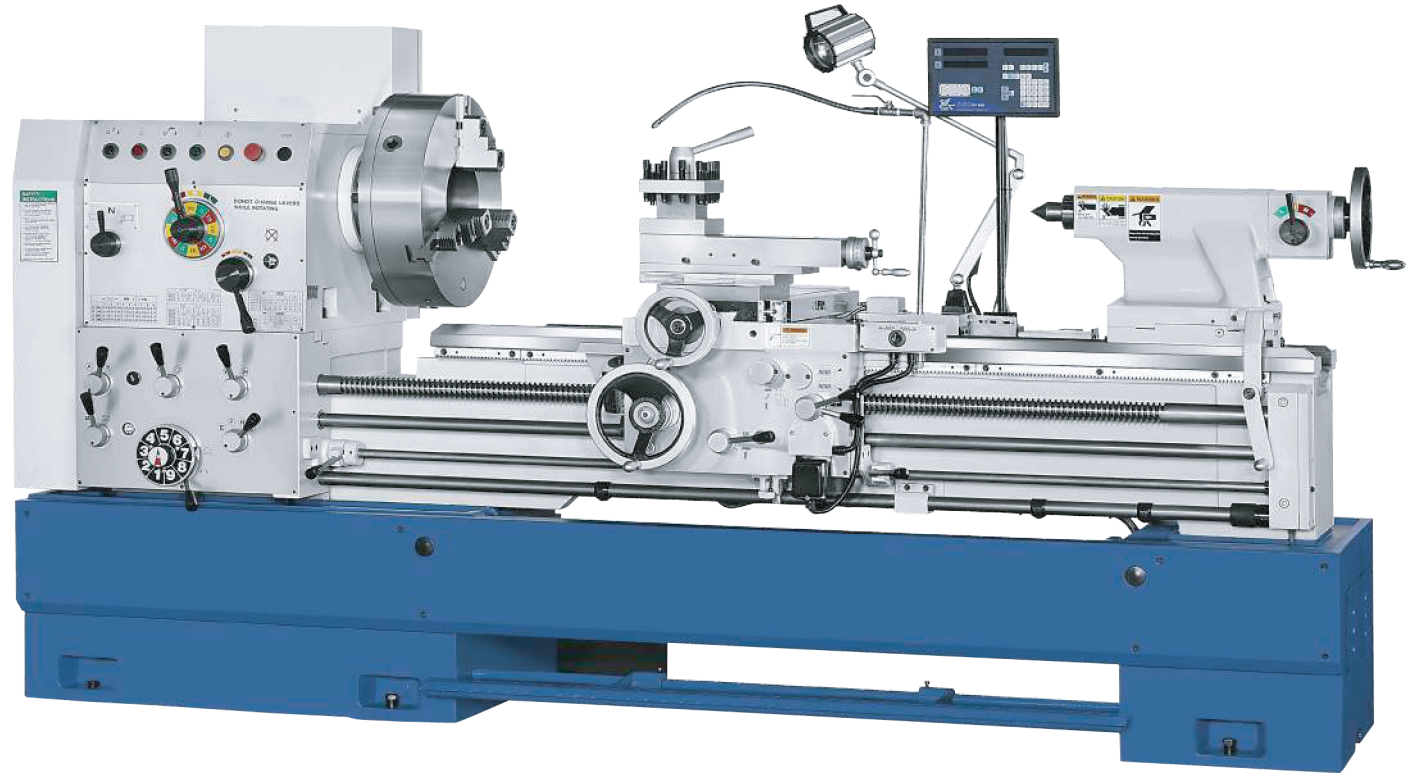

▶ MPA600

// LOADING CAPACITY

Between Spindle Center & Tailstock Center	Between Spindle Center & Tailstock Center & One Steady Rest	Between Spindle Center & Tailstock Center & Two Steady Rest	Only One Chuck
2500 KG / 5500 LB	3500 KG / 7700 LB	4500 KG / 9900 LB	250 KG / 550 LB

// SPECIFICATION

Below information is for reference only.



Precision Series		Unit	MPA600	MPA670	MPA770
Machining Area	Center Height	mm	300	335	385
	Swing over Bed	mm	600	670	770
	Swing over Cross Slide	mm	390	460	560
	Swing over Gap	mm	820	890	990
	Width of Bed	mm	400		
	Distance Between Centers	mm	1500 ~ 4000		
Headstock	Spindle Bore	mm	Ø80 (3") Ø104 (4")		
	Spindle Nose		A2-8 / D1-8 A2-11 / D1-11		
	Spindle Speeds	rpm	17 - 1200 15 - 1000		
	Number of Spindle Speeds		12 12		
	Main Spindle Motor	HP	15 15		
Feed	Number of Feeds		36		
	Longitudinal Feeds	mm/rev	0.05 - 0.7		
	Cross Feeds	mm/rev	0.025 - 0.35		
Threads	Metric Thread Range	mm (Kinds)	0.8 - 14 (65)		
	Inch Thread Range	TPI (Kinds)	2 - 28 (36)		
	Module Thread Range	MP (Kinds)	0.5 - 7 (22)		
	DP Thread Range	DP (Kinds)	4 - 56 (36)		
Carriage	Cross Slide Travel	mm	300	300	385
	Compound Rest Travel	mm	230		
Tailstock	Quill Diameter	mm	80		
	Quill Taper		MT5		
	Quill Travel	mm	230		

// OPTIONAL ACCESSORY FOR MPA

To check the accessory pictures, turn to page 21 and 22.

No.	Optional Accessory	Specification	MPA600/B3 MPA670/B3 MPA770/B3	MPA600/B4 MPA670/B4 MPA770/B4
01	3-Jaw Scroll Chuck	Diameter (inch)	10" / 12"	12" / 16"
02	4-Jaw Chuck	Diameter (inch)	16" / 20"	20"
22	Enclosed Rear Chuck Guard		NO	Y
12	Quick Change Toolpost	□25	Y	Y
13	Boring Device	≤Ø120 mm	Y	Y
15	Grinding Device	Wheel Size: 305 x 25 x 101.6 mm	Y	Y
07	Follow Rest	Ø30 - 150	Y	Y
08	Steady Rest	Range (mm)	50 - 380	50 - 380
19	Taper Attachment	400 mm ± 10°	Y	Y
05	Turret Type 4 Position Bed Stopper		Y	Y
06	Micro-Meter Bed Stopper		Y	Y
20	Full Length Rear Splash Guard		Y	Y
23	Tool Post Guard		Y	Y
24	Front Chuck Guard		Y	Y
17	Heavy Duty Live Center	MT5	Y	Y
16	Scissor-type Lifting Fixture		Y	Y

PRECISION LATHE - 18" BED



Heavy Duty Precision Lathe is a very popular product line in metal industry. The spindle motor power in the series is transmitted to the spindle through pulley, belt and 12-step gear sets. It could perform heavy duty machining with high speed and high rigidity.

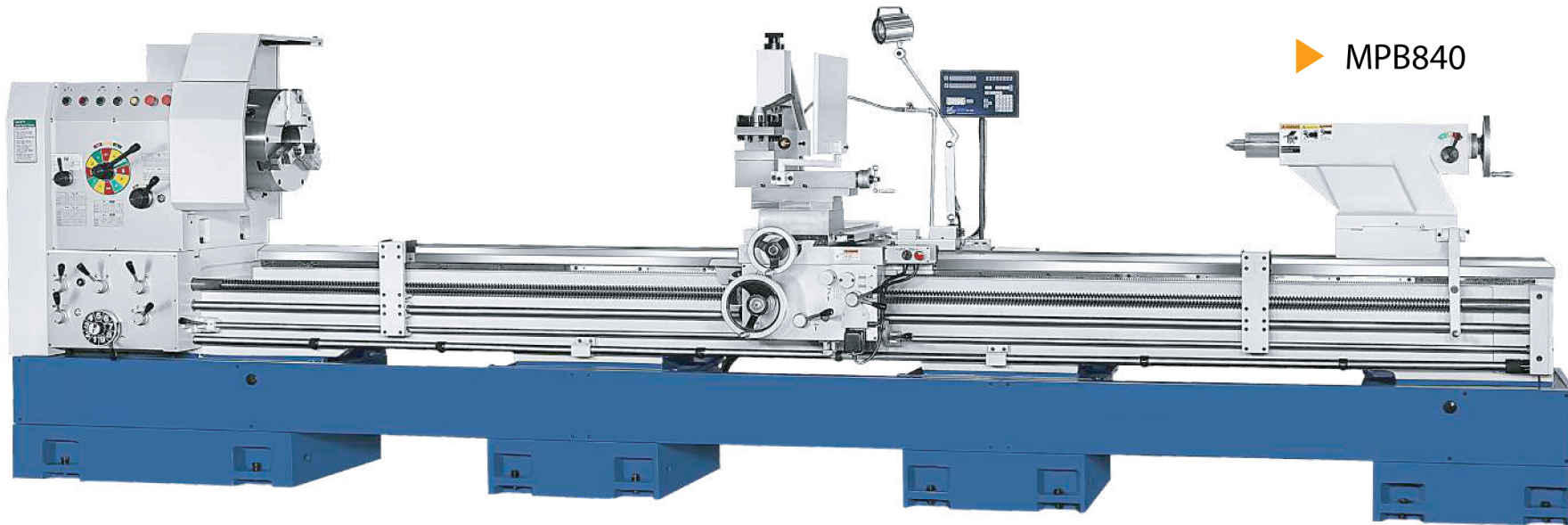

▶ MPB840

// LOADING CAPACITY

Between Spindle Center & Tailstock Center	Between Spindle Center & Tailstock Center & One Steady Rest	Between Spindle Center & Tailstock Center & Two Steady Rest	Only One Chuck
4000 KG / 8800 LB	5000 KG / 11000 LB	6000 KG / 13200 LB	500 KG / 1100 LB

// SPECIFICATION

Below information is for reference only.



Precision Series		Unit	MPB670	MPB770	MPB840
Machining Area	Center Height	mm	335	385	420
	Swing over Bed	mm	670	770	840
	Swing over Cross Slide	mm	460	560	630
	Swing over Gap	mm	890	990	1060
	Width of Bed	mm	460		
	Distance Between Centers	mm	1500 ~ 5000		
Headstock	Spindle Bore	mm	Ø104 (4")	156 (6")	230 (9")
	Spindle Nose		A2-11, D1-11	A2-11, D1-11	A2-15
	Spindle Speeds	rpm	15 - 1000	13 - 800	10 - 600
	Number of Spindle Speeds		12	12	12
	Main Spindle Motor	HP	15	15	15
Feed	Number of Feeds		36		
	Longitudinal Feeds	mm/rev	0.05 - 0.7		
	Cross Feeds	mm/rev	0.025 - 0.35		
Threads	Metric Thread Range	mm (Kinds)	0.8 - 14 (65)		
	Inch Thread Range	TPI (Kinds)	2 - 28 (36)		
	Module Thread Range	MP (Kinds)	0.5 - 7 (22)		
	DP Thread Range	DP (Kinds)	4 - 56 (36)		
Carriage	Cross Slide Travel	mm	385	435	435
	Compound Rest Travel	mm	230		
Tailstock	Quill Diameter	mm	95		
	Quill Taper		MT5		
	Quill Travel	mm	230		

// OPTIONAL ACCESSORY FOR MPB

To check the accessory pictures, turn to page 21 and 22.

No.	Optional Accessory	Specification	MPB670/B4 MPB770/B4 MPB840/B4	MPB670/B6 MPB770/B6 MPB840/B6	MPB670/B9 MPB770/B9 MPB840/B9
01	3-Jaw Scroll Chuck	Diameter (inch)	12" / 16"	16" / 20"	25"
02	4-Jaw Chuck	Diameter (inch)	20"	20"	24" / 25"
22	Enclosed Rear Chuck Guard		Y	Y	Y
12	Quick Change Toolpost	□25	Y	Y	Y
13	Boring Device	≤Ø120 mm	Y	Y	Y
15	Grinding Device	Wheel Size: 305 x 25 x 101.6 mm	Y	Y	Y
07	Follow Rest	Ø30 - 150	Y	Y	Y
08	Steady Rest	Range (mm)	50 - 380 / 300 - 530	50 - 380 / 300 - 530	50 - 380 / 300 - 530
19	Taper Attachment	400 mm ± 10°	Y	Y	Y
05	Turret Type 4 Position Bed Stopper		Y	Y	Y
06	Micro-Meter Bed Stopper		Y	Y	Y
20	Full Length Rear Splash Guard		Y	Y	Y
23	Tool Post Guard		Y	Y	Y
24	Front Chuck Guard		Y	Y	Y
17	Heavy Duty Live Center	MT5	Y	Y	Y
16	Scissor-type Lifting Fixture		Y	Y	Y

OIL COUNTRY LATHE - 22" BED



Oil Country Lathe is a famous product line for oil and gas field services industry and metal industry. The design of machine can be modified either to big bore lathes equipped with double chucks at both sides of headstock, or provide a large swing for

a big work-piece. The machine is generally applied to oil pipes, big steel rollers, large diameter flanges, long shafts of ships, etc. Besides, the machine can equip with a rotary quill as an optional on the tailstock for better work-piece clamping.

▶ MOC1060



// LOADING CAPACITY

Between Spindle Center & Tailstock Center	Between Spindle Center & Tailstock Center & One Steady Rest	Between Spindle Center & Tailstock Center & Two Steady Rest	Only One Chuck
6000 KG / 13200 LB	7500 KG / 16500 LB	9000 KG / 19800 LB	2000 KG / 4400 LB

// SPECIFICATION

Below information is for reference only.



Oil Country Series		Unit	MOC960		MOC1060		MOC1200	
Machining Area	Center Height	mm	480		530		600	
	Swing over Bed	mm	960		1060		1200	
	Swing over Cross Slide	mm	650		750		890	
	Swing over Gap (DBC 1.5 ~ 4 m only)	mm	1510		1610		1750	
	Width of Bed	mm			560			
	Distance Between Centers	mm			1500 ~ 9000			
Headstock	Spindle Bore	mm	156 (6")	230 (9")	260 (10")	310 (12")	360 (14")	
	Spindle Nose		A2-11	A2-15	A2-15	A2-20	A2-20	
	Spindle Speeds	rpm	9 - 600	6 - 400	6 - 400	5 - 300	5 - 300	
	Number of Spindle Speeds		12	12	12	12	12	
	Main Spindle Motor	HP	25	25	25	25	25	
Feed	Number of Feeds				48			
	Longitudinal Feeds	mm/rev			0.13 - 1.92			
	Cross Feeds	mm/rev			0.065 - 0.96			
Threads	Metric Thread Range	mm (Kinds)			2 - 30 (48)			
	Inch Thread Range	TPI (Kinds)			1 - 15 (48)			
	Module Thread Range	MP (Kinds)			1 - 15 (32)			
	DP Thread Range	DP (Kinds)			2 - 30 (48)			
Carriage	Cross Slide Travel	mm			540			
	Compound Rest Travel	mm			300			
Tailstock	Quill Diameter	mm			140			
	Quill Taper				MT6			
	Quill Travel	mm			300			

// OPTIONAL ACCESSORY FOR MOC

To check the accessory pictures, turn to page 21 and 22.

No.	Optional Accessory	Specification	MOC960		MOC1060		MOC1060		MOC1060		
			/B6	/B6	/B9	/B9	/B10	/B12	/B14		
01	3-Jaw Scroll Chuck	Diameter (inch)	16" / 20"	16" / 20"	25"	25"	25"	25"	31.5" / 32"		
03	4-Jaw Chuck	Diameter (inch)	20" / 24"	20" / 24"	24" / 26"	24" / 26"	26"	28"	28"		
22	Enclosed Rear Chuck Guard		Y	Y	Y	Y	Y	Y	Y		
12	Quick Change Toolpost	□32	Y	Y	Y	Y	Y	Y	Y		
13	Boring Device	Ø150 / Ø200 / Ø250	Y	Y	Y	Y	Y	Y	Y		
15	Grinding Device	Wheel: 350 x 38 x 152.4 mm	Y	Y	Y	Y	Y	Y	Y		
07	Follow Rest	Ø35 - 170 mm	Y	Y	Y	Y	Y	Y	Y		
09	Steady Rest	Range (mm)	150 - 380	150 - 380	150 - 380	150 - 380	150 - 380	150 - 380	150 - 380		
			300 - 530	300 - 530	300 - 530	300 - 530	300 - 530	300 - 530	300 - 530	300 - 530	
				500 - 780		500 - 780	500 - 780	500 - 780	500 - 780	500 - 780	
18	Hydraulic Copy Device	Stroke: X-120mm, Z-full length	NO	Y	NO	Y	Y	Y	Y		
19	Taper Attachment	500 mm ± 10°	Y	Y	Y	Y	Y	Y	Y		
05	Turret Type 4 Position Bed Stopper		Y	Y	Y	Y	Y	Y	Y		
20	Full Length Rear Splash Guard		Y	Y	Y	Y	Y	Y	Y		
23	Tool Post Guard		Y	Y	Y	Y	Y	Y	Y		
21	Sliding Front Chuck Guard		Y	Y	Y	Y	Y	Y	Y		
17	Heavy Duty Live Center	MT6	Y	Y	Y	Y	Y	Y	Y		
25	Auto Rapid Threading Device		NO	Y	NO	Y	Y	Y	Y		

HEAVY DUTY OIL COUNTRY LATHE - 32" BED



Oil Country Lathe is a famous product line for oil and gas field services industry and metal industry. The design of machine can be modified either to big bore lathes equipped with double chucks at both sides of headstock, or provide a large swing for

a big work-piece. The machine is generally applied to oil pipes, big steel rollers, large diameter flanges, long shafts of ships, etc. Besides, the machine can equip with a rotary quill as an optional on the tailstock for better work-piece clamping.

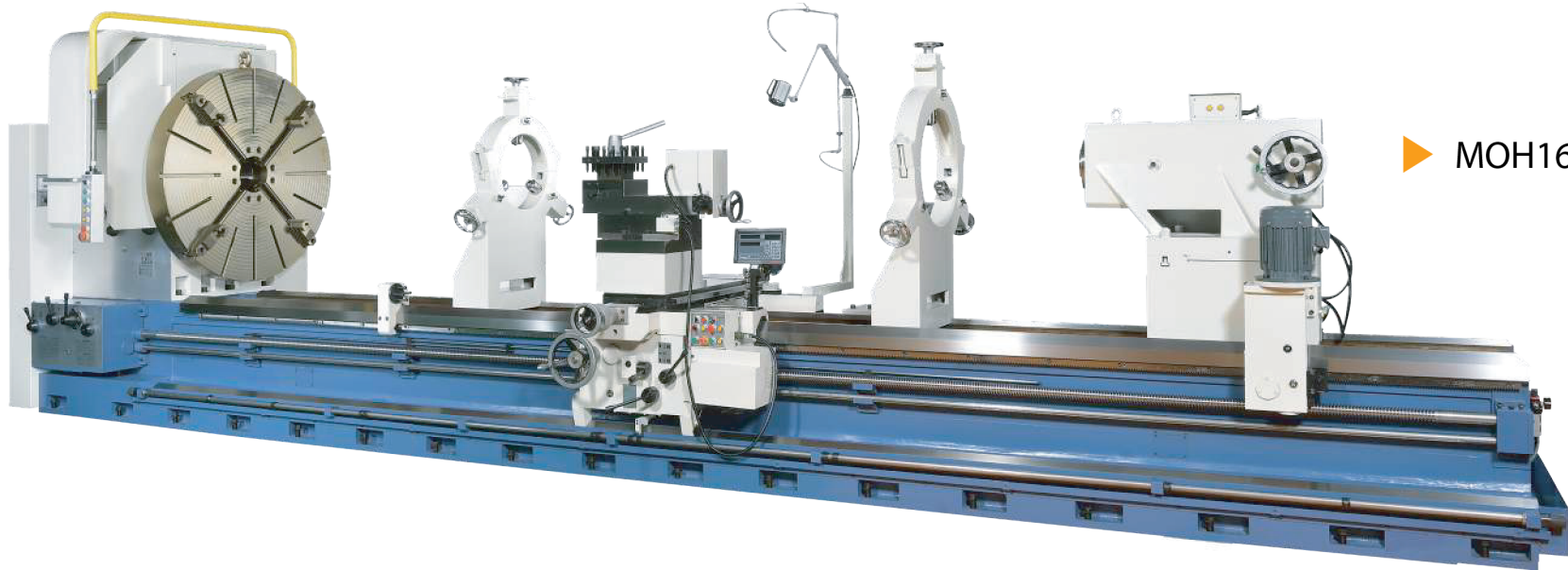

▶ MOH1600

// LOADING CAPACITY

A. Spindle Bore $\phi 230$, Tailstock Quill $\phi 200$
 B. Spindle Bore $\phi 230$, Tailstock Quill $\phi 290$

C. Spindle Bore $\phi 156 / \phi 260 / \phi 310 / \phi 360 / \phi 410 / \phi 535$, Tailstock Quill $\phi 200 / \phi 290$

	Between Spindle Center & Tailstock Center	Between Spindle Center & Tailstock Center & One Steady Rest	Between Spindle Center & Tailstock Center & Two Steady Rest	Only One Chuck
A	10000 KG / 22000 LB	12000 KG / 26400 LB	14000 KG / 30800 LB	4000 KG / 8800 LB
B	15000 KG / 33000 LB	17000 KG / 37400 LB	19000 KG / 41800 LB	4000 KG / 8800 LB
C	10000 KG / 22000 LB	12000 KG / 26400 LB	14000 KG / 30800 LB	4000 KG / 8800 LB

// SPECIFICATION

Below information is for reference only.



Oil Country Series		Unit	MOH1200		MOH1400		MOH1600		
Machining Area	Center Height	mm	600		700		800		
	Swing over Bed	mm	1190		1385		1580		
	Swing over Cross Slide	mm	830		1030		1230		
	Swing over Gap (DBC 2 ~ 4 m only)	mm	1750		1950		2150		
	Width of Bed	mm	800						
	Distance Between Centers	mm	2000 ~ 15000						
Headstock	Spindle Bore	mm	156 (6")	230 (9")	260 (10")	310 (12")	360 (14")	410 (16")	535 (21")
	Spindle Nose		A2-15	A2-15	A2-15	A2-20	A2-20	A2-28	A2-28
	Spindle Speeds	rpm	9 - 550	6 - 400	6 - 400	5 - 300	5 - 300	3 - 230	3 - 230
	Number of Spindle Speeds		12	12	12	12	12	12	12
	Main Spindle Motor	HP	30	30	30	30	30	30	30
Feed	Number of Feeds		48						
	Longitudinal Feeds	mm/rev	0.13 - 1.92						
	Cross Feeds	mm/rev	0.065 - 0.96						
Threads	Metric Thread Range	mm (Kinds)	2 - 30 (48)						
	Inch Thread Range	TPI (Kinds)	1 - 15 (48)						
	Module Thread Range	MP (Kinds)	1 - 15 (32)						
	DP Thread Range	DP (Kinds)	2 - 30 (48)						
Carriage	Cross Slide Travel	mm	780						
	Compound Rest Travel	mm	350						
Tailstock	Quill Diameter	mm	200						
	Quill Taper		MT7						
	Quill Travel	mm	300						

// OPTIONAL ACCESSORY FOR MOH

To check the accessory pictures, turn to page 21 and 22.

No.	Optional Accessory	Specification	MOH1200/B6	MOH1200/B9	MOH1200/B10	MOH1200/B12	MOH1200/B14	MOH1200/B16	MOH1200/B21
			MOH1400/B6	MOH1400/B9	MOH1400/B10	MOH1400/B12	MOH1400/B14	MOH1400/B16	MOH1400/B21
			MOH1600/B6	MOH1600/B9	MOH1600/B10	MOH1600/B12	MOH1600/B14	MOH1600/B16	MOH1600/B21
01	3-Jaw Scroll Chuck	Diameter (inch)	25"	25"	25"	25"	31.5"	NO	NO
03	4-Jaw Chuck	Diameter (inch)	26"	26"	26"	28"	28"	32"	36" / 40"
22	Enclosed Rear Chuck Guard		Y	Y	Y	Y	Y	Y	Y
14	Quick Change Toolpost	□40	Y	Y	Y	Y	Y	Y	Y
13	Boring Device	Ø150 / Ø200 / Ø250	Y	Y	Y	Y	Y	Y	Y
15	Grinding Device	Wheel Diameter: 350mm	Y	Y	Y	Y	Y	Y	Y
07	Follow Rest	Ø40 - 240 mm	Y	Y	Y	Y	Y	Y	Y
09	Steady Rest	Range (mm) <i>*For MOH1400 & MOH1600 only</i>	150-430	150-430	150-430	150-430	150-430	150-430	150-430
			350-630	350-630	350-630	350-630	350-630	350-630	350-630
			600-880	600-880	600-880	600-880	600-880	600-880	600-880
			<i>*800-1100</i>	<i>*800-1100</i>	<i>*800-1100</i>	<i>*800-1100</i>	<i>*800-1100</i>	<i>*800-1100</i>	<i>*800-1100</i>
11	Hydraulic Rear Supporting Stand		Y	Y	Y	Y	Y	Y	Y
19	Taper Attachment	500 mm ± 10°	Y	Y	Y	Y	Y	Y	Y
18	Hydraulic Copy Device	Stroke: X-120mm, Z-full length	Y	Y	Y	Y	Y	Y	Y
25	Auto Rapid Threading Device		Y	Y	Y	Y	Y	Y	Y
05	Turret Type 4 Position Bed Stopper		Y	Y	Y	Y	Y	Y	Y
20	Full Length Rear Splash Guard		Y	Y	Y	Y	Y	Y	Y
23	Tool Post Guard		Y	Y	Y	Y	Y	Y	Y
21	Sliding Front Chuck Guard		Y	Y	Y	Y	Y	Y	Y

GIANT FOUR GUIDEWAY LATHE - 52" BED



Giant Four Guideway Lathe is a specialized type of flat-bed lathe equipped with one wide bed and 2 pairs of guideways.

The tailstock and steady rests are placed on the pair of guideways at the rear side. Thus, the machine can be built the carriage goes crossing the 4 guideways called full length cross slide as a standard model design. The feature of high stiffness is able to stand for heavy duty machining with full cross slide travel.

▶ MGF2500

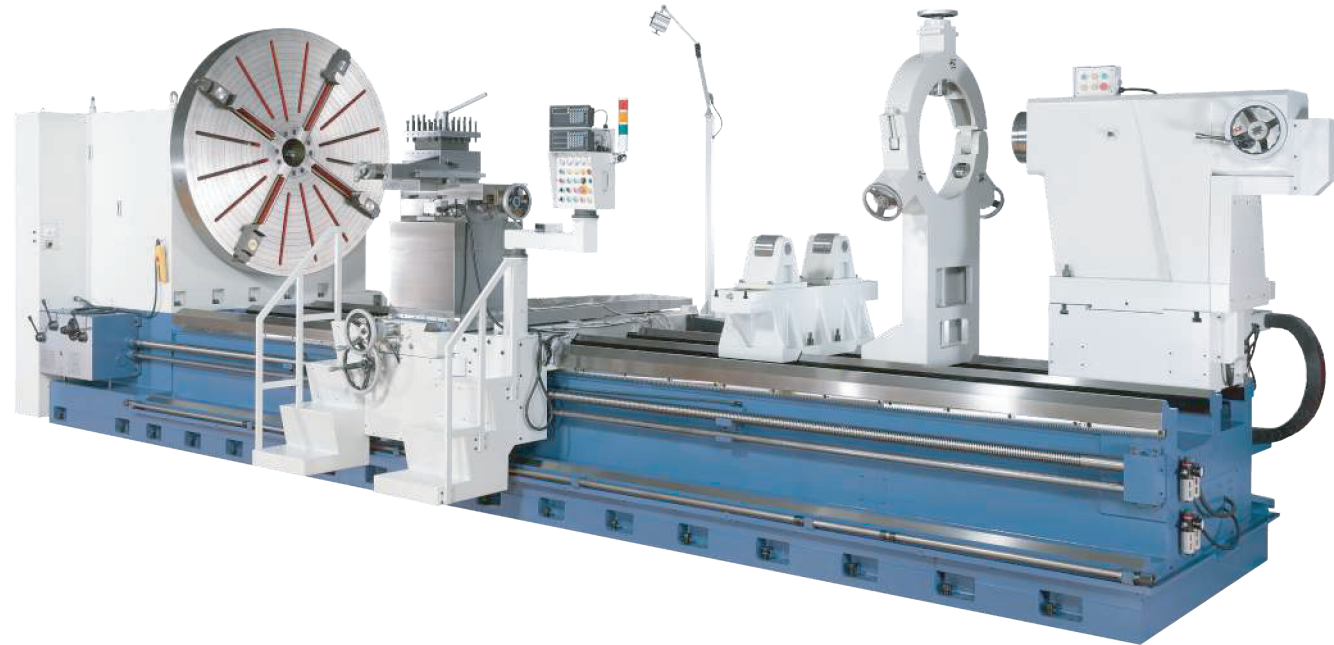

// LOADING CAPACITY

	Between Spindle Center & Tailstock Center	A. Tailstock Quill $\phi 290$ Between Spindle Center & Tailstock Center & One Steady Rest	B. Tailstock Quill $\phi 350$ & A2-20 Between Spindle Center & Tailstock Center & Two Steady Rest	Only One Chuck
A	25000 KG / 55000 LB	28000 KG / 61600 LB	31000 KG / 68200 LB	8000 KG / 17600 LB
B	33000 KG / 72600 LB	36000 KG / 79200 LB	39000 KG / 85800 LB	8000 KG / 17600 LB

// SPECIFICATION

Below information is for reference only.

Multi-Guideway Series		Unit	MGF1800	MGF2000	MGF2250	MGF2500
Machining Area	Center Height	mm	900	1000	1125	1250
	Swing over Bed	mm	1800	2000	2250	2500
	Swing over Cross Slide	mm	1350	1550	1800	2050
	Width of Bed	mm	1345			
	Distance Between Centers	mm	3000 ~ 12000			
Headstock	Spindle Bore	mm	210			
	Spindle Nose		A2-15 (A2-20 Opt.)			
	Spindle Speeds	rpm	5 - 400 (Infinite Adjustment by Inverter)			
	Number of Spindle Speeds		4			
	Main Spindle Motor	HP	75			
Feed	Number of Feeds		48			
	Longitudinal Feeds	mm/rev	0.13 - 1.92			
	Cross Feeds	mm/rev	0.065 - 0.96			
Threads	Metric Thread Range	mm (Kinds)	2 - 30 (48)			
	Inch Thread Range	TPI (Kinds)	1 - 15 (48)			
Carriage	Cross Slide Travel	mm	1200			
	Compound Rest Travel	mm	U: 250; W: 350			
Tailstock	Quill Diameter	mm	290			
	Quill Taper		MT7			
	Quill Travel	mm	300			

// OPTIONAL ACCESSORY FOR MGF

To check the accessory pictures, turn to page 21 and 22.

No.	Optional Accessory	Specification	MGF1800	MGF2000	MGF2250	MGF2500
03	4-Jaw Chuck	Diameter (inch)	55" / 60" / 63"	63" / 72"	72" / 80"	80"
04	Face Plate	Diameter (inch)	55" / 60" / 63"	60" / 63" / 72"	72" / 80" / 87"	80" / 87"
14	Boring Device	Ø150 / Ø200 / Ø250	Y	Y	Y	Y
10	Steady Rest	Range (mm)	180 - 450	180 - 450	180 - 450	180 - 450
			350 - 650	350 - 650	350 - 650	350 - 650
			600 - 900	600 - 900	600 - 900	600 - 900
			800 - 1100	800 - 1100	800 - 1100	800 - 1100
20	Full Length Rear Splash Guard		Y	Y	Y	Y
21	Sliding Front Chuck Guard		Y	Y	Y	Y

CUSTOMIZED GIANT LATHE - 72" BED



MGX is a giant lathe with 72" width of bed designed by totally customized solutions. This model of Machines can be configured to clients requirements. Trying to understand in depth what our customer needs is the most important thing for us to be able to offer the ideal solutions to generate a feasible proposal.

- 2600 ~ 3600mm swings.
- 1830mm bed width with four-guideway bed structure for high stiffness.

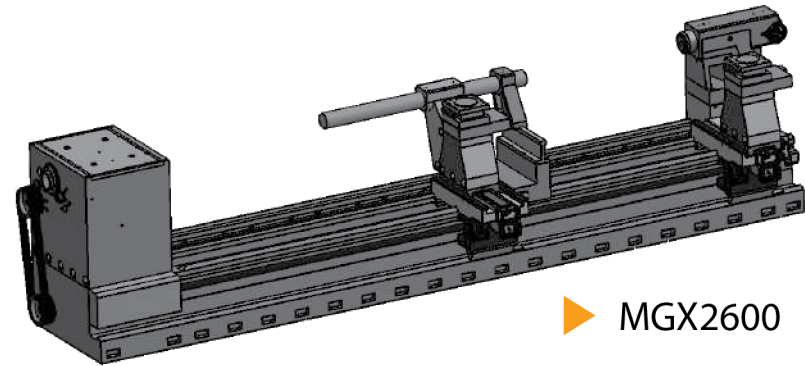

▶ MGX2600

// LOADING CAPACITY

Between Spindle Center & Tailstock Center

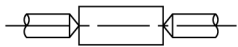

A. Tailstock Quill $\phi 350$
33000 KG / 72600 LB

B. Tailstock Quill $\phi 450$
40000 KG / 88100 LB

// SPECIFICATION

Below information is for reference only.

	Multi-Guideway Series	Unit	MGX2600	MGX3100	MGX3600
Machining Area	Center Height	mm	1325	1575	1825
	Swing over Bed	mm	2600	3100	3600
	Swing over Cross Slide	mm	2100	2600	3100
	Width of Bed	mm	1830		
	Distance Between Centers	mm	3000 ~ 12000		
Headstock	Spindle Bore	mm	180		
	Spindle Nose		A2-20 (A2-28 Opt.)		
	Spindle Speeds		2 - 200 (Infinite Adjustment by Inverter)		
	Number of Spindle Speeds	rpm	4		
Feed	Main Spindle Motor	HP	100		
	Number of Feeds		48		
	Longitudinal Feeds	mm/rev	0.13 - 1.92		
Threads	Cross Feeds	mm/rev	0.065 - 0.96		
	Metric Thread Range	mm (Kinds)	2 - 30 (48)		
	Inch Thread Range	TPI (Kinds)	1 - 15 (48)		
Carriage	Cross Slide Travel	mm	950		
	Compound Rest Travel	mm	U: 200; W: 400		
Tailstock	Quill Diameter	mm	350		
	Quill Taper		MT7		
	Quill Travel	mm	250		

AUTO RAPID THREADING FUNCTION

Available for   

This function is **user-friendly** operation when doing thread-cutting, especially for the machine with a big spindle bore.

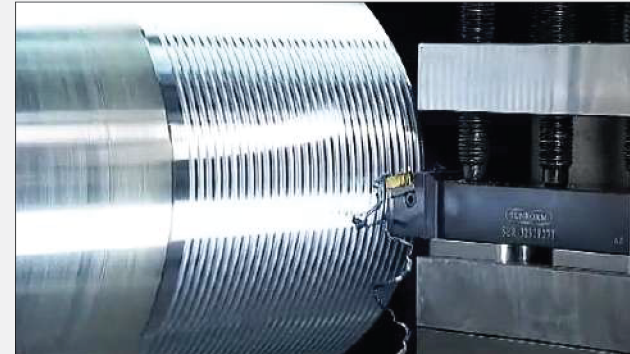

// FEATURE

- Automatic toolpost forwarding and retracting, operators **ONLY** need to increase tooling depth at beginning of each cycle.
- It's driven by hydraulic cylinder.
- The threading feeding is transmitted by half nuts and lead screw. This mechanism is traditional and reliable.

// WORKING STEPS

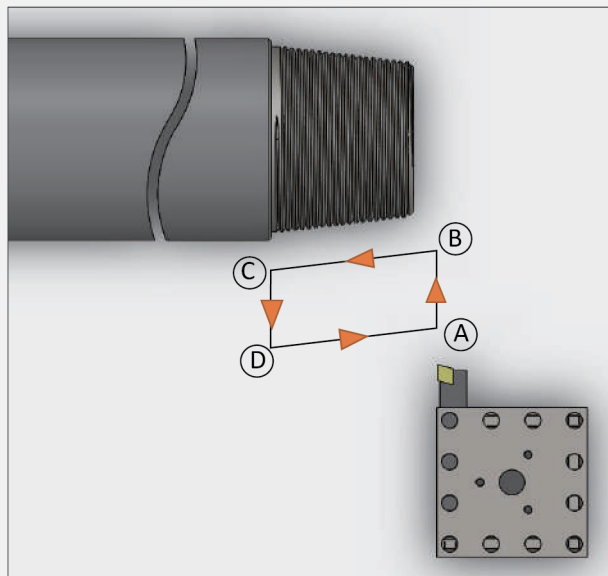

1. **A** → **B** when function ON.
2. **B** activated by half nuts engage to lead screw.
3. **C** → **D** → **A** activated by limit switch.

Auto Tool Forwarding : CONVENIENT!
→ Tool insert returns to previous cutting diameter automatically.

Auto Retracting : OPERATION SAFETY!
→ Tool path is managed by limit switches and sensors.

Auto Homing : TIME SAVING!
→ Hydraulic cylinder pulls carriage back to the beginning of the travel.

MODEL SELECTION

Model	Swing over Bed	Swing over Cross Slide	Swing over Gap	Width of Bed		DBC (m)*
				Main Bedways	W/ Auxiliary Guideway	
MPA600	600	390	820	400	---	1.5 ~ 4
MPA670	670	460	890	400	---	1.5 ~ 4
MPA770	770	560	990	400	---	1.5 ~ 4
MPB670	670	460	890	460	---	1.5
MPB670	670	460	890	460	---	2 ~ 5
MPB770	770	560	990	460	---	1.5
MPB770	770	560	990	460	---	2 ~ 5
MPB840	840	630	1060	460	---	1.5
MPB840	840	630	1060	460	---	2 ~ 5
MOC960	960	650	1510	560	660	1.5 ~ 4
MOC960	960	650	---	560	660	5 ~ 9
MOC1060	1060	750	1610	560	660	1.5 ~ 4
MOC1060	1060	750	---	560	660	5 ~ 9
MOC1200	1200	890	1750	560	660	1.5 ~ 4
MOC1200	1200	890	---	560	660	5 ~ 9

*Customized longer DBC is available in MOC, MOH, MGF and MGX series for specific applications.

Model	DBC (m)*	Spindle Bore (mm)								
		80	104	156	230	260	310	360	410	535
MPA600	1.5 ~ 4	●	●							
MPA670	1.5 ~ 4	●	●							
MPA770	1.5 ~ 4	●	●							
MPB670	1.5		●	●						
MPB670	2 ~ 5		●	●	●					
MPB770	1.5		●	●						
MPB770	2 ~ 5		●	●	●					
MPB840	1.5		●	●						
MPB840	2 ~ 5		●	●	●					
MOC960	1.5 ~ 4			●	●					
MOC960	5 ~ 9			●	●					
MOC1060	1.5 ~ 4			●	●	●	●	●		
MOC1060	5 ~ 9			●	●	●	●	●		
MOC1200	1.5 ~ 4			●	●	●	●	●		
MOC1200	5 ~ 9			●	●	●	●	●		

▲ Big bores are by customization, please discuss with our sales rep.

MODEL SELECTION

Model	Swing over Bed	Swing over Cross Slide	Swing over Gap	Width of Bed		DBC (m)*
				Main Bedways	W/ Auxiliary Guideway	
MOH1200	1190	830	1750	800	1000	2 ~ 4
MOH1200	1190	830	---	800	1000	5 ~ 15
MOH1400	1385	1030	1950	800	1000	2 ~ 4
MOH1400	1385	1030	---	800	1000	5 ~ 15
MOH1600	1580	1230	2150	800	1000	2 ~ 4
MOH1600	1580	1230	---	800	1000	5 ~ 15
MGF1800	1800	1350	---	1345	1575	3 ~ 12
MGF2000	2000	1550	---	1345	1575	3 ~ 12
MGF2250	2250	1800	---	1345	1575	3 ~ 12
MGF2500	2500	2050	---	1345	1575	3 ~ 12
MGX2600	2600	2100	---	1830	TBA	3 ~ 12
MGX3100	3100	2600	---	1830	TBA	3 ~ 12
MGX3600	3600	3100	---	1830	---	3 ~ 12

*Customized longer DBC is available in MOC, MOH, MGF and MGX series for specific applications.

Model	DBC(m)*	Spindle Bore (mm)										
		80	104	156	180	210	230	260	310	360	410	535
MOH1200	2 ~ 4			●			●	●	●	●	●	●
MOH1200	5 ~ 15			●			●	●	●	●	●	●
MOH1400	2 ~ 4			●			●	●	●	●	●	●
MOH1400	5 ~ 15			●			●	●	●	●	●	●
MOH1600	2 ~ 4			●			●	●	●	●	●	●
MOH1600	5 ~ 15			●			●	●	●	●	●	●
MGF1800	3 ~ 12					●	▲	▲	▲	▲	▲	▲
MGF2000	3 ~ 12					●	▲	▲	▲	▲	▲	▲
MGF2250	3 ~ 12					●	▲	▲	▲	▲	▲	▲
MGF2500	3 ~ 12					●	▲	▲	▲	▲	▲	▲
MGX2600	3 ~ 12				●							
MGX3100	3 ~ 12				●							
MGX3600	3 ~ 12				●							

▲ Big bores are by customization, please discuss with our sales rep.

OPTIONAL ACCESSORY

01 3-Jaw Scroll Chuck



02 4-Jaw Chuck



03 4-Jaw Chuck



04 Face Plate



05 Turret Type 4 Position Bed Stopper



06 Micro-Meter Bed Stopper



07 Follow Rest



08 Steady Rest



09 Steady Rest



10 Steady Rest



11 Hydraulic Rear Supporting Stand

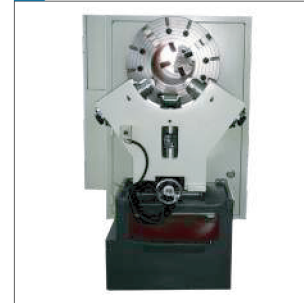

12 Quick Change Toolpost



13 Boring Device



14 Boring Device



15 Grinding Device



16 Scissor-type Lifting Fixture



17 Heavy Duty Live Center

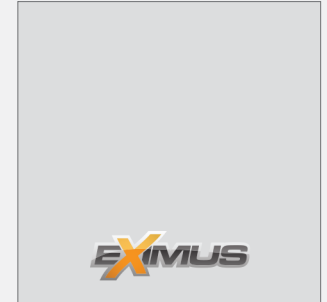

18 Hydraulic Copy Device

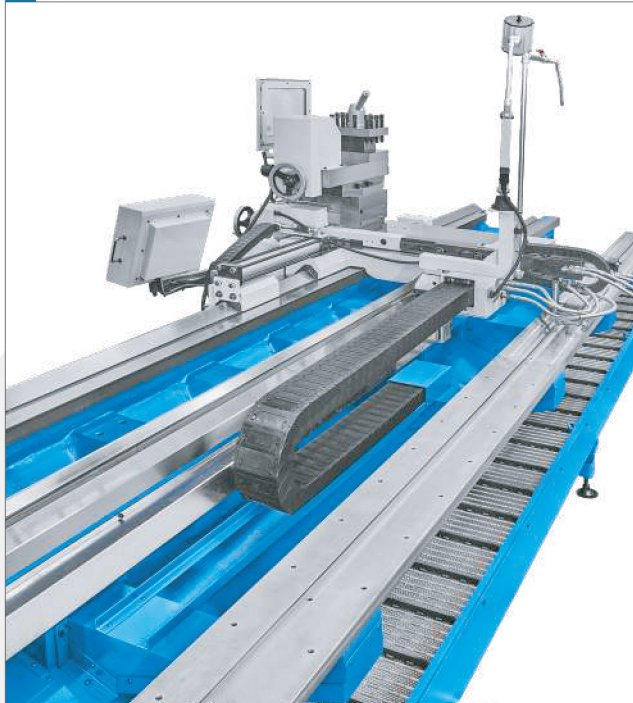

19 Taper Attachment



20 Full Length Rear Splash Guard



21 Sliding Front Chuck Guard



22 Enclosed Rear Chuck Guard



23 Tool Post Guard



24 Front Chuck Guard



25 Auto Rapid Threading Device



BUILDING
GREAT MACHINES
MAKES...



T. // +61 7 3219 4000

E. // sales@whitelawmachinery.com.au

A. // 128 Lytton Rd, Hemmant QLD 4174

whitelawmachinery.com.au