

“The Sky Hook Industrial Lifting Device has reduced our turbine engine removal time by 50%. It’s a big hit around here!”

-Mike Maul, Manufacturing Engineer, Elliott Microturbines



Attitude is Everything!

MODEL 8500 SERIES



- Designed to fit most quick-change tool holders
- Load limit 500 lbs. (227 kg)
- Weighs 23 lbs. (10.4 kg)
- Prevents lifting injuries
- Does the work of 4 people
- Meets O.S.H.A. requirements

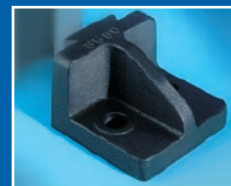

Accessory 8500-00A Bolt Down Adapter shown above (Sold separately)

Model 8500 Series has multiple lifting applications when used with accessory bolt down adapter. (See chart below)

Model 8500 Series comes with a base designed for your specific tool holder. See the Model Selection Chart below for the correct model # for your needs.



Accessory 8520 Chuck Hook shown above (Sold separately)

Lifting Applications

Ideal for lifting chucks, vises and large pieces of material onto lathes, mills, benches and other equipment.

Model 8500 Series Selection Chart

Sky Hook Model #	Fits Tool Holder	Accessory Bolt Down Adapter (Sold separately)
8500-00	KDK 100, 150, 200, NIX	8500-00A
8500-01	Square Turret or 3/4" Tool Block	No Adapter
8500-02	CA Aloris, Dorian SD40CA, DTM TP100A, Phase II 400	8500-02-AS
8500-02A	BXA Aloris, Dorian SD30BXA, DTM TP75A, Phase II 200	8500-02A-AS
8500-03	CXA Aloris, Dorian SD35CXA, DTM TP90A, Phase II 300	8500-03-AS
8500-04	KDK 300	8500-04-AS
8500-05	DA Aloris, Dorian SD50DA	8500-05-AS

industry leader since 1969

SKY HOOK

MODEL 8500 SERIES

The Sky Hook Lifting Device Model 8500 Series prevents back injuries and is ideal for lifting chucks, vises and large pieces of material onto lathes, mills, benches and other equipment. Weighing only 23 lbs, Sky Hook Model 8500 Series pivots 360° for precision positioning. Safe and simple to use, this model easily lifts up to 500 lbs. With a base designed for your specific tool holder, its one-handed operation does the work of four people in a single step.

Less expensive than a forklift, overhead crane, or chain hoist, Sky Hook Model 8500 Series is a safe lifting solution that answers almost any need. User friendly and adaptable, it makes the job of rotating and positioning a 500-lb. object turnkey.

Easily detached and carried to different locations, this practical, adaptable, labor-saving lifting device is ideal for all general applications. For specialty applications, custom units of Sky Hook Model 8500 Series are also available.

For more descriptive product info visit www.skyhookmfr.com

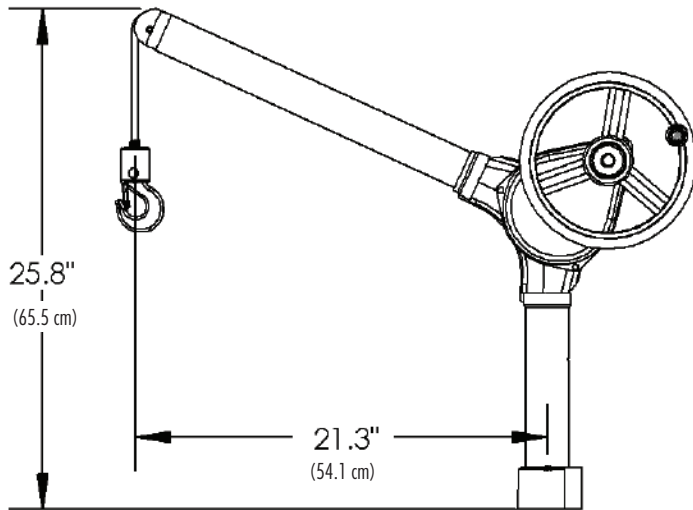

Specifications

- Load limit 500 lbs. (227 kg)
- Weighs 23 lbs. (10.4 kg)
- Pivots 360°
- 55" (139.7 cm) Length of lift
- Overall height of Sky Hook including base is 25.8" (65.5 cm)
- One rotation of hand wheel = approx. 1" (2.5 cm) of vertical lift
- Models to fit most quick change tool holders
- Easily detached and carried to different locations
- Constructed of high-strength steel



Features & Benefits

- Designed to fit most quick-change tool holders
- Prevents lifting injuries
- Uses one hand operation that does the work of 4 people
- Safely lift & position up to 500 lbs. (227 kg) with one person
- Rotates 360°
- Designed for precision positioning
- Operates in tight working conditions
- Is totally maintenance free
- Has removable boom for easy transport
- Has a limited manufacturer's warranty
- Meets applicable O.S.H.A. requirements

Accessories



Bolt Down Adapter
(Model 8500-00A
shown above, See Model
Selection Chart on reverse)



**Choker Collar
Accessory**
Model 8507

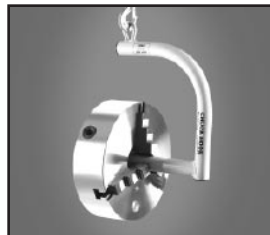

**Chuck Hook
Accessory**
Model 8520

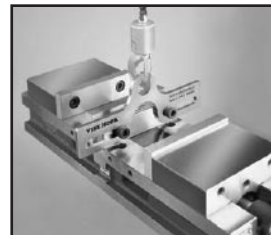

**Vise Hook
Accessory**
Model 8515



**Nylon Sling
Accessory**
Model 8510 Series



Attitude is Everything!

www.skyhookmfr.com

ATTCO, INC. DBA
SYCLONE ATTCO SERVICE
P.O. Box 458, Emmett, ID 83617

800-4SKYHOOK (800-475-9466)

Fax: 800-973-3355

E-mail: info@skyhookmfr.com

“The Sky Hook Model 8527 turned an arduous task into something simple and assured us of back injury prevention.”

-Sgt. Eric Womack, San Diego Harbor Police



Attitude is Everything!

MODEL 8527



- Designed to bolt easily to any suitable flat surface
- Load limit 500 lbs. (227 kg)
- Sky Hook weighs 26 lbs. (11.8 kg)
- Base weighs 12 lbs. (5.4 kg)
- Prevents lifting injuries
- Does the work of 4 people
- Meets O.S.H.A. requirements

Lifting Applications

Ideal for mounting to bench, service truck/van or heavy cart to handle a large variety of general lifting applications.

industry leader since 1969

SKY HOOK

MODEL 8527 w/BOLT DOWN BASE

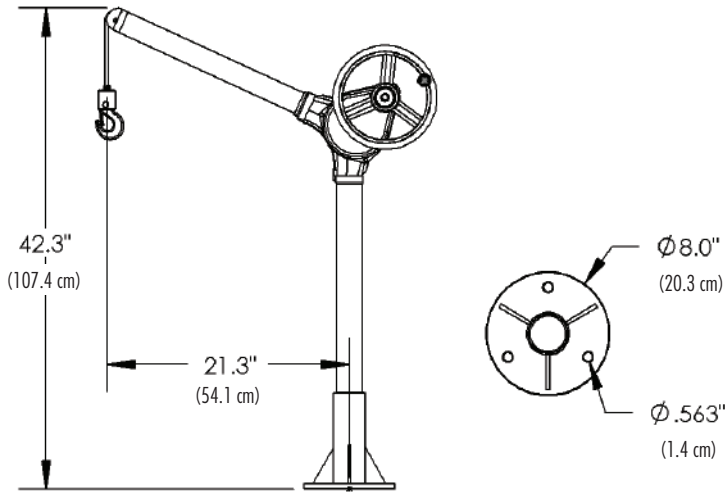

Sky Hook Model 8527 gives you the added muscle needed to prevent serious back injuries. Ideal for mounting to a bench, a service truck/van, or a heavy cart, Model 8527 is designed to make lifting safe, simple, and affordable.

The Sky Hook Model 8527 has a 75" length of lift that makes lifting up to 500 lbs. possible for one person, yet the Sky Hook itself weighs just 26 lbs. Crafted for consumers who usually need two or more people to move or lift machine parts or heavy items, Model 8527 pivots 360° for precision positioning.

Designed to mount onto any suitable flat surface, Sky Hook Model 8527 functions well in tight working conditions and is less expensive than a forklift, overhead crane, or chain hoist. Because its one-handed operation does the work of four people, Model 8527 is especially suited for those who need an effective yet totally maintenance-free lifting tool. For specialty applications, custom units of Sky Hook Model 8527 are also available.

For more descriptive product info visit www.skyhookmfr.com

Specifications



- Load limit 500 lbs. (227 kg)
- Sky Hook weighs 26 lbs. (12 kg)
- Base weighs 12 lbs. (5.4 kg)
- Pivots 360°
- 75" (190.5 cm) Length of lift
- Overall height of Sky Hook including base is 42.3" (107.4 cm)
- One rotation of hand wheel = approx. 1" (2.5 cm) of vertical lift
- Easily detached and carried to different locations
- Constructed of high-strength steel

Features & Benefits

- Designed to bolt easily to any suitable flat surface
- Prevents lifting injuries
- Uses one hand operation that does the work of 4 people
- Safely lift & position up to 500 lbs. (227kg) with one person
- Rotates 360°
- Designed for precision positioning
- Operates in tight working conditions
- Is totally maintenance free
- Has removable boom for easy transport
- Has a limited manufacturer's warranty
- Meets applicable O.S.H.A. requirements

Accessories



Choker Collar
Accessory Model 8507



Chuck Hook
Accessory Model 8520

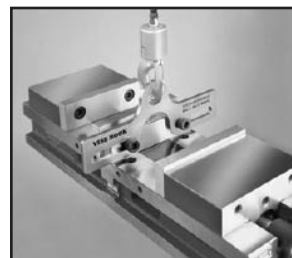

Vise Hook
Accessory Model 8515



Nylon Sling
Accessory Model 8510
Series



Attitude is Everything!

www.skyhookmfr.com

ATTCO, INC. DBA
SYCLONE ATTCO SERVICE
P.O. Box 458, Emmett, ID 83617

800-4SKYHOOK (800-475-9466)

Fax: 800-973-3355

E-mail: info@skyhookmfr.com

"I was so impressed with this portable lifting device; I even bought the Sky Hook Model 8540 w/Receiver Hitch base for my personal use. It fits on my truck, as well as with the Sky Hook Model 8557 base stand in my home shop."

-Robert L Walker, Aerospace Engineering Tech, NASA's Ames Research Center



Attitude is Everything!

MODEL 8540



Designed to fit standard 2" receiver hitch

- Designed to load and unload materials or heavy awkward items with the convenience of a receiver hitch mount
- Load limit 500 lbs. (227 kg)
- Sky Hook weighs 26 lbs. (11.8 kg)
- Base weighs 21 lbs. (9.5 kg)
- Prevents lifting injuries
- Does the work of 4 people
- Meets O.S.H.A. requirements



Lifting Applications

Ideal for sliding into the receiver hitch of a truck or service van to handle a large variety of lifting applications.

industry leader since 1969

SKY HOOK

MODEL 8540 w/RECEIVER HITCH BASE

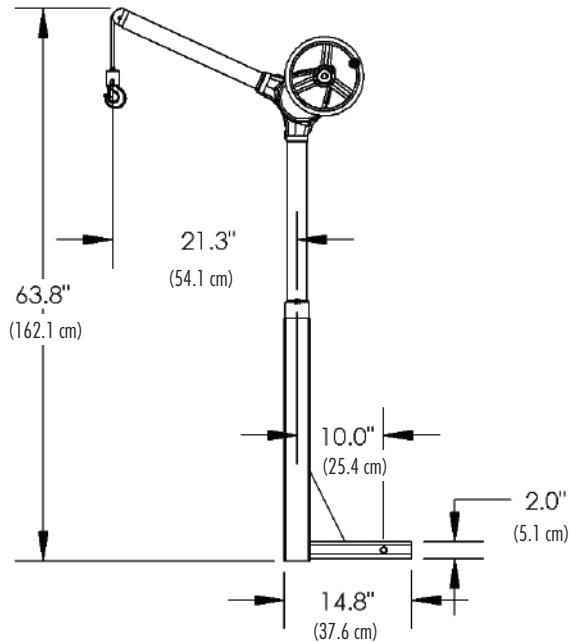

Specifications

- Load limit 500 lbs. (227 kg)
- Sky Hook weighs 26 lbs. (11.8 kg)
- Base weighs 21 lbs. (9.5 kg)
- Pivots 360°
- 75" (190.5 cm) Length of lift
- Overall height of Sky Hook including base is 63.8" (162.1 cm)
- One rotation of hand wheel = approx. 1" (2.5 cm) of vertical lift
- T-Handle to lock rotation
- Constructed of high-strength steel

Accessories



Choker Collar
Accessory Model 8507



Chuck Hook
Accessory Model 8520

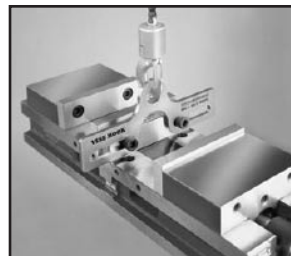

Vise Hook
Accessory Model 8515



Nylon Sling
Accessory Model 8510 Series

Sky Hook Model 8540 w/Receiver Hitch Base is designed specifically for lifting and loading or unloading of items into–or out of–your service van or truck. Lightweight, portable, and easily detached, Model 8540 is great for do-it-yourselfers, mechanics, repairmen, movers, contractors, and anyone with a heavy item that needs safe lifting. Whether you want to lift machine parts or lumber, generators or pumps, Model 8540 allows you to lift and position up to 500 lbs. without the need for electricity.

As you safely load onto or unload out of vehicle's bed– using only one hand–Model 8540 does the work of four people for less than the cost of a forklift. This precision engineered solution is also easily disassembled for storage, giving you flexibility wherever you need to transport materials or heavy and awkward items.

Model 8540 slips directly into a standard 2" Class 3 receiver hitch and has a T-Handle to prevent rotation when not in use. For specialty applications, custom units of Sky Hook Model 8540 are also available.

For more descriptive product info visit www.skyhookmfr.com

Features & Benefits

- Designed to load and unload materials or heavy awkward items with the convenience of a receiver hitch mount
- No drilling or welding required
- Prevents lifting injuries
- Uses one hand operation that does the work of 4 people
- Rotate 360°
- One person can safely lift & position up to 500 lbs. (227 kg)
- Designed for precision positioning
- Totally maintenance free
- Boom removable for easy storage
- Disassembles for transport
- Has a limited manufacturer's warranty
- Meets applicable O.S.H.A. requirements



Attitude is Everything!

www.skyhookmfr.com

ATTCO, INC. DBA
SYCLONE ATTCO SERVICE
P.O. Box 458, Emmett, ID 83617

800-4SKYHOOK (800-475-9466)

Fax: 800-973-3355

E-mail: info@skyhookmfr.com

“The Sky Hook does all the work, helping us prevent back injuries. Machine accessory lifting in our crowded area is no longer a problem.”

-Andy Alexander, Benlan Inc.



Attitude is Everything!

MODEL 8550

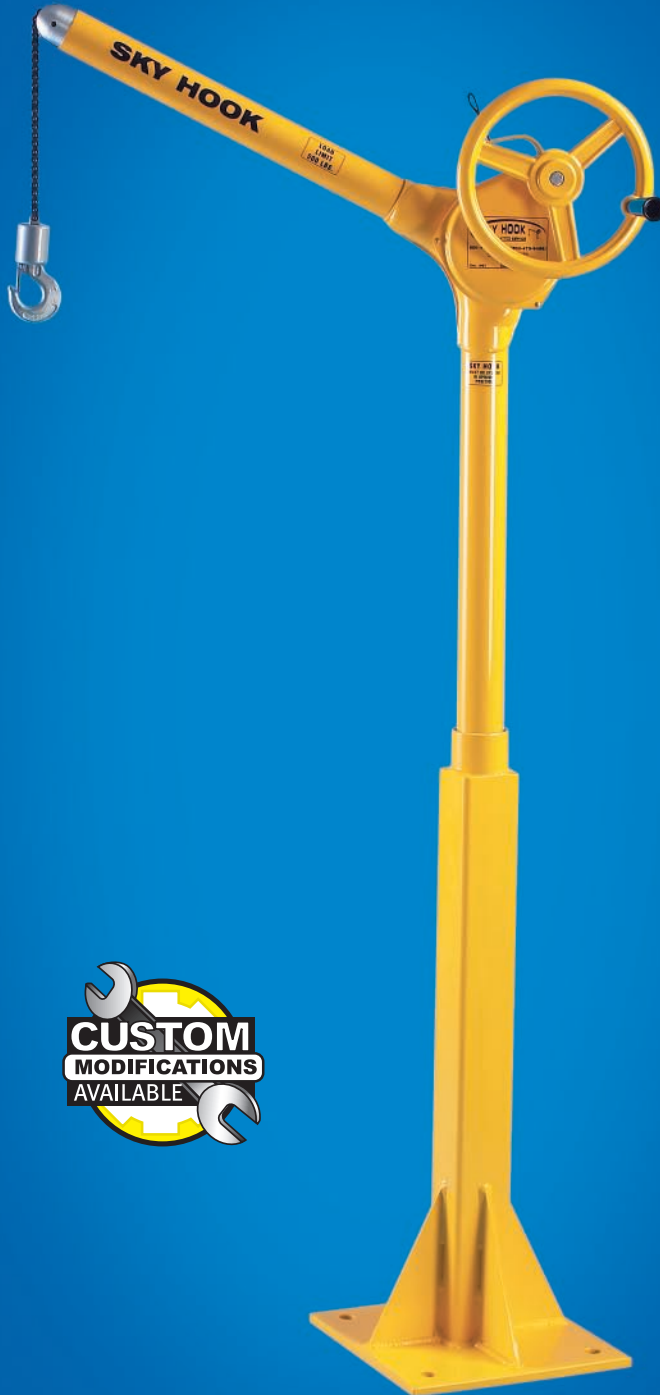

- Designed to bolt easily to floor or any suitable flat surface
- Load limit 500 lbs. (227 kg)
- Sky Hook weighs 26 lbs. (11.8 kg)
- Base weighs 42 lbs. (19.1 kg)
- Prevents lifting injuries
- Does the work of 4 people
- Meets O.S.H.A. requirements

Lifting Applications

Ideal for mounting to floor near machine or equipment to handle a large variety of lifting applications.

industry leader since 1969

SKY HOOK

MODEL 8550 w/FLOOR MOUNT BASE

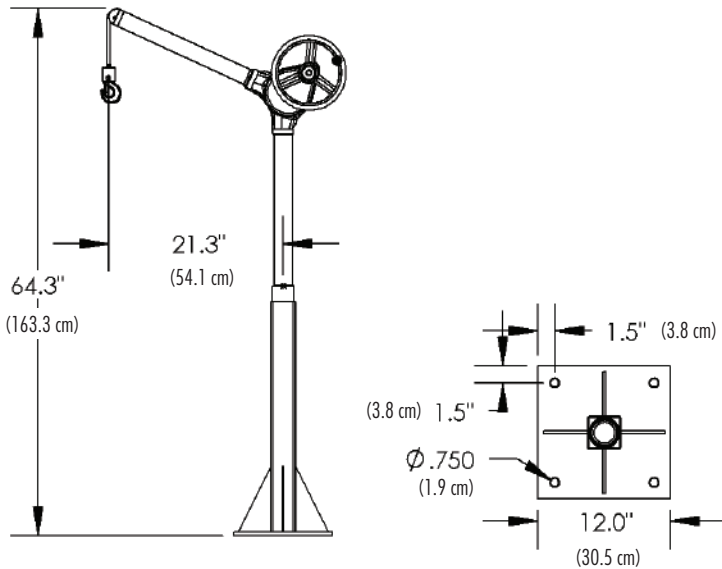

Designed to bolt easily to floors, Sky Hook Model 8550

is perfect for those applications where you want a unit ready to do the heavy lifting sitting right next to your machine or equipment. This versatile unit works well in welding departments, assembly and production areas, repair stations, loading docks, marine docks, and boat or ship decks.

Using just one person, the Sky Hook Model 8550 makes lifting up to 500 lbs. possible—yet the Sky Hook itself weighs just 26 lbs. Additionally, with Model 8550 just one person can safely lift and pivot the load 360° for precision positioning. As an added benefit, Sky Hook Model 8550 functions well in tight working conditions and is less expensive than a forklift, overhead crane, or chain hoist.

If you need to move or lift machine parts or heavy items, you're at risk for back sprains, muscle pulls, wrist injuries, elbow injuries, spinal injuries, and other damage caused by lifting heavy objects. Sky Hook Model 8550 reduces those risks and does the heavy lifting for you. For specialty applications, custom units of Sky Hook Model 8550 are also available.

For more descriptive product info visit www.skyhookmfr.com

Specifications

- Load limit 500 lbs. (227 kg)
- Sky Hook weighs 26 lbs. (11.8 kg)
- Base weighs 42 lbs. (19.1 kg)
- Pivots 360°
- 75" (190.5 cm) Length of lift
- Overall height of Sky Hook including base is 64.3" (163.3 cm)
- One rotation of hand wheel = approx. 1" (2.5 cm) of vertical lift
- Easily detached and carried to different locations
- Constructed of high-strength steel



Features & Benefits

- Designed to bolt easily to floor or any suitable flat surface
- Prevents lifting injuries
- Uses one hand operation that does the work of 4 people
- Safely lifts & position up to 500 lbs. (227kg) with one person
- Rotates 360°
- Designed for precision positioning
- Operates in tight working conditions
- Totally maintenance free
- Has removable boom for easy transport
- Has a limited manufacturer's warranty
- Meets applicable O.S.H.A. requirements

Accessories



Choker Collar
Accessory Model 8507



Chuck Hook
Accessory Model 8520

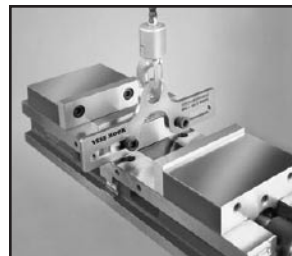

Vise Hook
Accessory Model 8515



Nylon Sling
Accessory Model 8510 Series



Attitude is Everything!

www.skyhookmfr.com

ATTCO, INC. DBA
SYCLONE ATTCO SERVICE
P.O. Box 458, Emmett, ID 83617

800-4SKYHOOK (800-475-9466)

Fax: 800-973-3355

E-mail: info@skyhookmfr.com

“The Sky Hook Model 8557 is working beyond our expectations... We have two units and are looking at purchasing a third because it functions so well for all of our air conditioning compressor installations.”

-Jeffrey A., Medical Systems customer



Attitude is Everything!

MODEL 8557



- Designed to straddle the corner of benches, pallets, etc.
- Load limit 500 lbs. (227 kg)
- Sky Hook weighs 26 lbs. (11.8 kg)
- Base weighs 92 lbs. (41.7)
- Prevents lifting injuries
- Does the work of 4 people
- Meets O.S.H.A. requirements

Lifting Applications

Perfect for any lifting and moving application. Ideal for tight, hard-to-reach locations where you can't get other lifting devices or multiple people to assist you.

industry leader since 1969

SKY HOOK

MODEL 8557 w/MOBILE BASE

The **Sky Hook Lifting Device Model 8557** is a lightweight portable, manual lifting device ideal for tight, hard-to-reach areas where you can't get other lifting devices or multiple people to assist you. Model 8557 is the solution for lifting and transporting items off of and onto benches or pallets and is great for general material handling such as pulling out pumps, motors, and other parts. Model 8557 is ideal for maintenance and service departments and costs less than a forklift or crane—with the added benefit of maneuverability.

It's easy to take it just about anywhere—even to a job site— because Sky Hook Model 8557 easily disassembles into sections weighing 34 lbs. or less. The added value of 360° rotation with the ability to straddle the corner of benches, pallets, etc. makes it the perfect portable, manual lifting device for you.

Back injuries and manpower are reduced because Sky Hook Model 8557 can be used by one person to safely lift and position up to 500 lbs. For specialty applications, custom units of Sky Hook Model 8557 are also available.

For more descriptive product info visit www.skyhookmfr.com

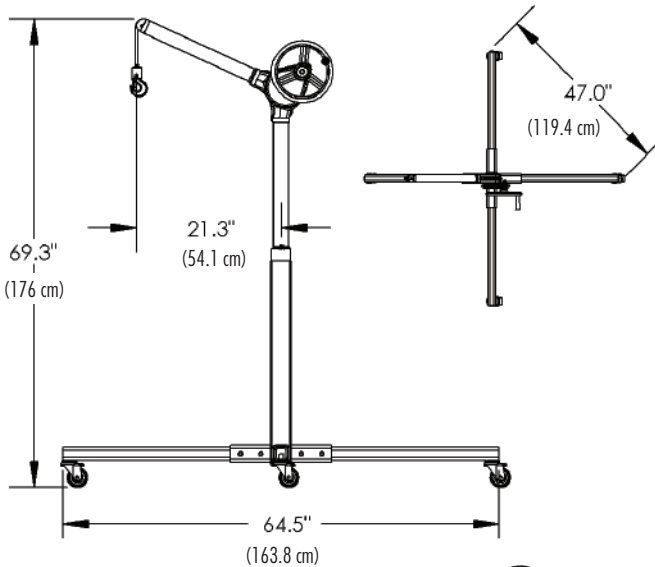

Specifications

- Load limit 500 lbs. (227 kg)
- Sky Hook weighs 26 lbs. (11.8 kg)
- Base weighs 92 lbs. (41.7 kg)
- Pivots 360°
- 75" (190.5 cm) Length of lift
- Overall height of Sky Hook from floor is 69.3" (176 cm)
- One rotation of hand wheel = approx. 1" (2.5 cm) of vertical lift
- Easily detached and carried to different locations
- Four swivel casters for portable lifting
- Constructed of high-strength steel

Features & Benefits

- Designed to straddle the corner of benches, pallets, etc.
- Prevents lifting injuries
- Rotates 360°
- Uses one hand operation that does the work of 4 people
- Safely lift & position up to 500 lbs. (227 kg) with one person
- Designed for precision positioning
- Operates in tight working conditions
- Is totally maintenance free
- Has removable boom
- Disassembles for transport
- Has a limited manufacturer's warranty
- Meets applicable O.S.H.A. requirements

Accessories



Choker Collar
Accessory Model 8507



Chuck Hook
Accessory Model 8520

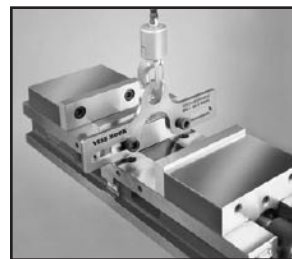

Vise Hook
Accessory Model 8515



Nylon Sling
Accessory Model 8510 Series



Attitude is Everything!

www.skyhookmfr.com

ATTCO, INC. DBA
SYCLONE ATTCO SERVICE
P.O. Box 458, Emmett, ID 83617

800-4SKYHOOK (800-475-9466)

Fax: 800-973-3355

E-mail: info@skyhookmfr.com

“At Nampa Valley Helicopters, industrial accident prevention is always foremost. When we evaluated ergonomic lifting equipment, preventing back injuries was a key. Sky Hook is doing the job so well here at Nampa Valley Helicopters, we need another unit!”

-John Nielson, Nampa Valley Helicopters, Inc.



Attitude is Everything!

MODEL 8560



Accessory 8510 Series Nylon Sling shown above
(Sold separately)

- Designed to lift heavy or awkward objects without the need for a counterweight
- Load limit 500 lbs. (227 kg)
- Sky Hook weighs 26 lbs. (11.8 kg)
- Base weighs 78 lbs. (35.4 kg)
- Prevents lifting injuries
- Does the work of 4 people
- Meets O.S.H.A. requirements

Lifting Applications

Ideal for any lifting and moving application. This compact, stable design is perfect for tight, hard-to-reach locations.

industry leader since 1969

SKY HOOK

MODEL 8560 w/CHERRY PICKER BASE

Sky Hook Model 8560 w/Cherry Picker Base is perfect for lifting heavy or awkward objects from their shipping or packaging materials because its one-handed operation does the work of four people. Smaller and more agile than the traditional cherry picker, Model 8560's compact design makes it perfect for tight, hard-to-reach areas.

Ideal for straddling a crate—and also designed so the legs can go under something without requiring a counterweight—Model 8560 is an efficient and easy way to have enough leverage to retrieve the item you need to move. Unlike other cherry picker designs, Model 8560 has the flexibility of 15° rotation in each direction from center, allowing a full 30° range of motion when working in tight areas.

Designed to pass through narrow doors and tight hard-to-reach areas, Model 8560 functions well in all buildings (not just large plants) and is less expensive than a forklift, overhead crane, or chain hoist. For specialty applications, custom units of Sky Hook Model 8560 are also available.

For more descriptive product info visit www.skyhookmfr.com

Features & Benefits

- Designed to lift heavy or awkward objects without the need for a counterweight
- Prevents lifting injuries
- Uses one hand operation that does the work of 4 people
- Safely lift & position up to 500 lbs. (227 kg) with one person
- Designed for precision positioning
- Operates in tight working conditions
- Is totally maintenance free
- Has removable boom
- Disassembles for easy transport and storage
- Designed to fit a 3 ft. (91.4 cm) standard aisle and tight hard-to-reach areas
- Has a limited manufacturer's warranty
- Meets applicable O.S.H.A. requirements

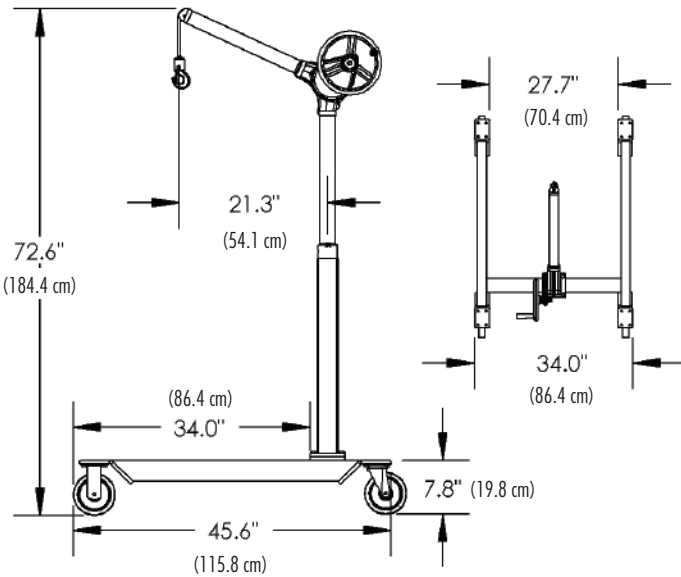

Specifications

- Load limit 500 lbs. (227 kg)
- Sky Hook weighs 26 lbs. (11.8 kg)
- Base weighs 78 lbs. (35.4 kg)
- Pivots 15° in each direction from center
- 75" (190.5 cm) Length of lift
- Overall height of Sky Hook from floor is 72.6" (184.4 cm)
- One rotation of hand wheel = approx. 1" (2.5 cm) of vertical lift
- 6" (15.2 cm) Casters allow for easy movement
- Fits through a standard 3'0" (91.4 cm) door
- Constructed of high-strength steel

Accessories



Choker Collar
Accessory Model 8507



Chuck Hook
Accessory Model 8520

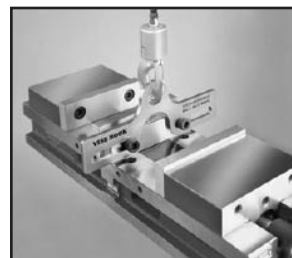

Vise Hook
Accessory Model 8515



Nylon Sling
Accessory Model 8510
Series



Attitude is Everything!

www.skyhookmfr.com

ATTCO, INC. DBA
SYCLONE ATTCO SERVICE
P.O. Box 458, Emmett, ID 83617

800-4SKYHOOK (800-475-9466)

Fax: 800-973-3355

E-mail: info@skyhookmfr.com

“Changing out moulds efficiently and safely—that’s what using the Sky Hook allows us to do. I recommend Sky Hook to anyone who does any machine accessory lifting.”

-Andy Alexander, Benlan Inc.



Attitude is Everything!

MODEL 8565



- Designed to reach into any area without legs under load
- Load limit 500 lbs. (227 kg)
- Sky Hook weighs 26 lbs. (11.8 kg)
- Base weighs 107 lbs. (48.5 kg)
- Prevents lifting injuries
- Does the work of 4 people
- Meets O.S.H.A. requirements



Accessory 8515 Vise Hook and Accessory CW1-8570 Individual Counterweight shown above (Sold separately)

Lifting Applications

Ideal for material handling, lifting and moving applications in: maintenance and repair facilities, shipping and receiving departments, production and assembly areas in manufacturing. This design allows easy access to work areas in tight, hard-to-reach locations.



COUNTERWEIGHT REQUIRED NOTE: Counterweight must be at least **125%** of lifted weight.

Option 1	Customer supplies own counterweight.	Counterweight used must be at least 125% of lifted weight.
Option 2	Accessory CW-8570 (Complete Counterweight Kit)	This kit, CW-8570, allows a load capacity of 500 lbs. to be lifted.
Option 3	Accessory CW1-8570 (Individual Counterweight)	If less than 500 lbs. capacity is needed, individual weights may be used.

industry leader since 1969

SKY HOOK

MODEL 8565 w/REVERSE CHERRY PICKER BASE

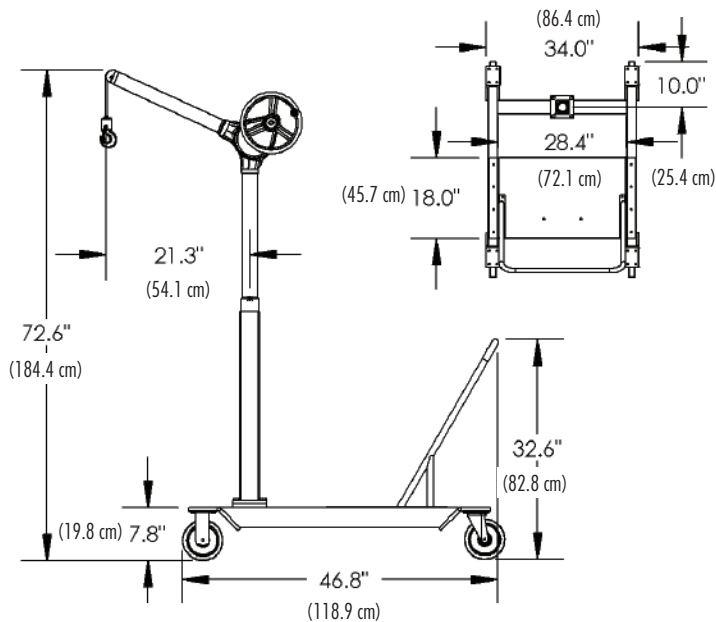

Specifications

- Load limit 500 lbs. (227 kg)
- Sky Hook weighs 26 lbs. (11.8 kg)
- Base weighs 107 lbs. (48.5 kg)
- Pivots 15° in each direction from center
- 75" (190.5 cm) Length of lift
- Overall height of Sky Hook from floor is 72.6" (184.4 cm)
- One rotation of hand wheel = approximately 1" (2.5 cm) of vertical lift
- 6" (15.2 cm) Casters allow for easy movement
- Fits through a standard 3'0" (91.4 cm) door
- Ergonomic handle for easy maneuverability
- Fully-welded counterweight tray included
- Constructed of high-strength steel
- Counterweight required (See options chart on front)



Accessories



Choker Collar
Accessory Model 8507



Chuck Hook
Accessory Model 8520

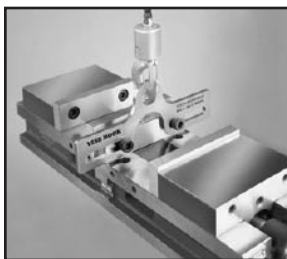

Vise Hook
Accessory Model 8515



Nylon Sling
Accessory Model 8510
Series



Attitude is Everything!

www.skyhookmfr.com

The compact design of Sky Hook Model 8565 w/Reverse Cherry Picker Base allows easy access into machinery to remove or reposition heavy or awkward items that need to be changed, modified or stored after use. With the flexibility of 15° rotation in each direction from center, Sky Hook Model 8565 allows you a full 30° range of motion when working in tight areas.

Sky Hook Model 8565 safely allows the installation or removal of key items because its one-handed operation does the work of four people. Without a tray to get in the way of the machinery, Model 8565's design allows you to get up close to the machine—making it ideal for CNC equipment. With an ergonomic handle for easy maneuverability, Model 8565 works well when lifting over or into equipment where legs cannot fit under, especially in tight areas.

Easily disassembled for transport, Sky Hook Model 8565 fits through a standard 3' 0" door and into tight, hard-to-reach areas. Model 8565 is also less expensive than a forklift, overhead crane, or chain hoist. For specialty applications, custom units of Sky Hook Model 8565 are also available.

For more descriptive product info visit www.skyhookmfr.com

Features & Benefits

- Designed to reach into any area without legs under load
- Prevents lifting injuries
- Uses one hand operation that does the work of 4 people
- Safely lift & position up to 500 lbs. (227 kg) with one person
- Designed for precision positioning
- Operates in tight working conditions
- Totally maintenance free
- Has removable boom
- Disassembles for easy transport and storage
- Designed to fit a 3 ft. (91.4 cm) standard aisle and tight, hard-to-reach areas
- Has a limited manufacturer's warranty
- Meets applicable O.S.H.A. requirements

ATTCO, INC. DBA

SYCLONE ATTCO SERVICE

P.O. Box 458, Emmett, ID 83617

800-4SKYHOOK (800-475-9466)

Fax: 800-973-3355

E-mail: info@skyhookmfr.com

“Model 8570 is so well-built that the uses never end. I ended up getting another unit and am now promoting it to all my gear machine manufacturers. Now that we have these units, I can’t imagine what we did without them!”

-Ross Deneau, Manufacturing Manager, Engineered Tools Corporation



Attitude is Everything!

MODEL 8570



Lifting Applications

Ideal for any lifting and moving application.

The Sky Hook Industrial Lifting Device Model 8570 is perfect for tight, hard-to-reach locations with the added convenience of a utility cart.



Accessory 8515 Vise Hook and Accessory CW1-8570 Individual Counterweight shown above (Sold separately)

- Designed to lift, transport and store machine accessories, material or heavy awkward items
- Load limit 500 lbs. (227 kg)
- Sky Hook weighs 26 lbs. (11.8 kg)
- Base weighs 178 lbs. (80.7 kg)
- Prevents lifting injuries
- Does the work of 4 people
- Meets O.S.H.A. requirements

COUNTERWEIGHT REQUIRED NOTE: Counterweight must be at least **125%** of lifted weight.

Option 1	Customer supplies own counterweight.	Counterweight used must be at least 125% of lifted weight.
Option 2	Accessory CW-8570 (Complete Counterweight Kit)	This kit, CW-8570, allows a load capacity of 500 lbs. to be lifted.
Option 3	Accessory CW1-8570 (Individual Counterweight)	If less than 500 lbs. capacity is needed, individual weights may be used.

industry leader since 1969

SKY HOOK

MODEL 8570 w/MOBILE CART

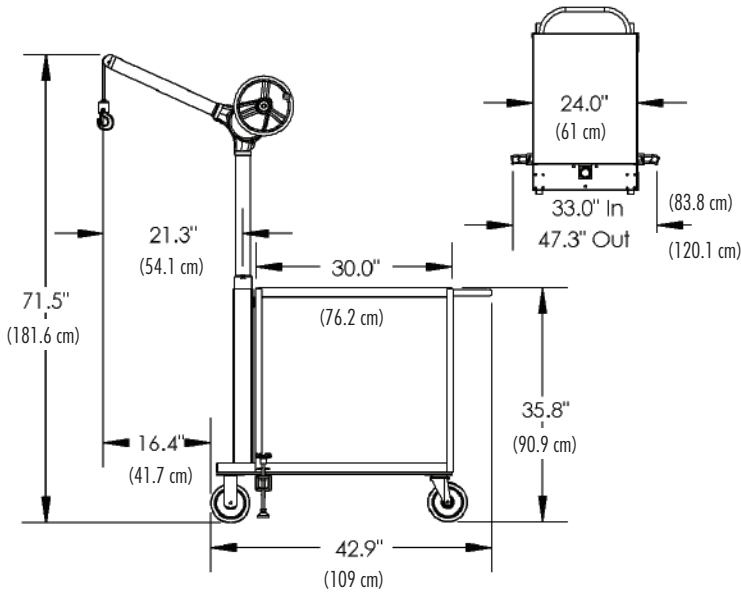

Sky Hook Model 8570 is a "mobile" version of the original Model 8527 Sky Hook. More flexible than an overhead crane, this mobile lifting device can be moved from location to location, and is designed to fit narrow aisles and tight, hard-to-reach areas. Model 8570 w/mobile cart allows you to lift, transport and store machine accessories, material, or heavy awkward items while preventing serious back injuries.

Sky Hook Model 8570 is ideal for customers with CNC equipment who need a manual lifting device with a mobile cart without legs extending under the machine. Also, Model 8570 has the added benefit of a top shelf for storing tools, materials, or components. CNC users are not our only Model 8570 users—this lifting device is also the ideal solution for many other general lifting applications.

Model 8570 allows you to reach into equipment, lift an object up to 500 lbs. and rotate it 360°. And—it gets into those tight areas you can't get to with a forklift! For specialty applications, custom units of Model 8570 are also available.

For more information visit www.skyhookmfr.com

Specifications

- Load limit 500 lbs. (227 kg)
- Sky Hook weighs 26 lbs. (11.8 kg)
- Base weighs 178 lbs. (80.7 kg)
- 75" (190.5 cm) Length of lift
- Overall height of Sky Hook from floor is 71.5" (181.6 cm)
- One rotation of hand wheel = approx. 1" (2.5 cm) of vertical lift
- 360° Rotation with outrigger legs extended
- Fits through a standard 3'0" (91.4 cm) door
- 6" (15.2 cm) Casters allow for easy movement
- Heavy duty 12ga. steel shelves
- Fully welded cart
- Constructed of high-strength steel
- Counterweight required (See options chart on front)



Features & Benefits

- Designed to lift, transport and store machine accessories, material or heavy awkward items
- Prevents lifting injuries
- Uses one hand operation that does the work of 4 people
- Safely lift & position up to 500 lbs. (227 kg) with one person
- Reaches easily into machine without legs under load
- Rotates 360° with outrigger legs extended
- Designed for precision positioning
- Operates in tight working conditions
- Designed to fit a 3 ft. (91.4 cm) standard aisle and tight, hard-to-reach areas
- Is totally maintenance free
- Has removable boom
- Has a limited manufacturer's warranty
- Meets applicable O.S.H.A. requirements

Accessories



**Choker Collar
Accessory Model 8507**



**Chuck Hook
Accessory Model 8520**

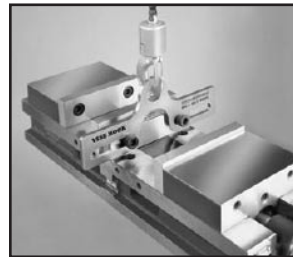

**Vise Hook
Accessory Model 8515**



**Nylon Sling
Accessory Model 8510
Series**



Attitude is Everything!

www.skyhookmfr.com

ATTCO, INC. DBA
SYCLONE ATTCO SERVICE
P.O. Box 458, Emmett, ID 83617

800-4SKYHOOK (800-475-9466)

Fax: 800-973-3355

E-mail: info@skyhookmfr.com

“I described my lifting requirements to Dean at Sky Hook and he said, ‘No problem, we can do that.’ In no time at all, we were able to lift parts easily. Our experience with the Sky Hook product and the customer service was excellent.”

- Sgt. Eric Womack, San Diego Harbor Police



Attitude is Everything!

CUSTOMIZE

Modifications:

- Longer boom
- Taller vertical
- Lowered hand wheel
- Wedge-shaped base w/counterweight box
- Cleanroom



Application:

Custom base designed to fit into a wedge-shaped space between two pieces of equipment. Longer boom and taller vertical to reach up and over to access specialty equipment for maintenance. Cleanroom modifications for fab in semiconductor company.

Modifications:

- Taller vertical
- Lowered hand wheel
- Cut fixture hole in top shelf of cart



Application:

Modifications allow the special refrigeration unit at NASA's Ames Research Center to be lifted straight up, swung around and placed in the fixture hole of the cart for maintenance.

Modifications:

- Shorter boom
- Shorter vertical

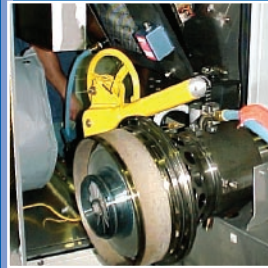

Application:

Shorter reach & vertical height required for Elliott Microturbine's internal turbine engine removal application in a very tight area.

Modifications:

- Taller vertical
- Lowered hand wheel
- Custom mobile base w/4 swivel casters
- Custom fixture frame



Application:

Designed for a lab to lift a 400 lb. lid. Allowed lid to be placed on frame for maintenance inside cold source vacuum module. Custom base w/4 swivel casters for maneuverability.

Modifications:

- Dual hand wheel
- Longer boom w/knee brace
- Shorter vertical
- Cleanroom
- Color to match their product (OEM)



Application:

Designed to lift sensitive tooling in cleanroom for routine maintenance. Dual hand wheel allows access from both sides. Shorter vertical and longer boom to fit and reach into confined space between the tooling and top of machine. Cleanroom modifications for fab in semiconductor company. White paint color to match Novellus Systems' product (OEM).



Modifications:

- 10 ft overall height
- Lowered hand wheel
- Stainless steel chain

Application:

Food processor needed to clean a machine with sharp knives that was too tall to safely strip down without a lifting device. A modified Sky Hook (10ft overall height w/lowered hand wheel) was created to reach the section of the machine. Stainless steel chain due to food industry environment was also used.



industry leader since 1969

SKY HOOK

CUSTOMIZE

Syclone ATTCO Service works with manufacturers and end-users in all types of industries to customize the Sky Hook for their safe lifting applications. Modifying any of our industrial lifting products to meet your lifting needs is an everyday occurrence. Our experienced staff is ready to help find the most effective solution to your safe lifting requirements.

Modified boom length:
Fit the Sky Hook to your exact reach requirements.

Stainless chain: Eliminates contamination in clean room & food industry environments as well as preventing corrosion in outdoor environments.

Modified height:
To safely reach under, over, or up to objects.

Modified color: To match your application or product for a unique feel.

Modified hand wheel location:
Select the side, or even a dual configuration for additional accessibility. Also, the hand wheel can be vertically positioned for specific ergonomic requirements.

These are some of the most popular modifications, however, the list goes on and on. Call us with your challenge.



Attitude is Everything!

www.skyhookmfr.com

ATTCO, INC. DBA

SYCLONE ATTCO SERVICE

P.O. Box 458, Emmett, ID 83617

800-4SKYHOOK (800-475-9466)

Fax: 800-973-3355

E-mail: info@skyhookmfr.com

“I’ve had such great experiences using the Sky Hook Model 8570 at work and using the Sky Hook Model 8450 w/ Receiver Hitch base for my own use – ordering the Choker Collar Model 8507 just makes sense! Thank you Sky Hook for making my life easier.”

-Robert L Walker, Aerospace Engineering Tech, NASA’s Ames Research Center



Attitude is Everything!

ACCESSORIES

Syclone ATTCO Service is always providing new solutions to help you get the most from your Sky Hook model. These accessories add even more safety, speed, and functionality to your Sky Hook lifting solution.

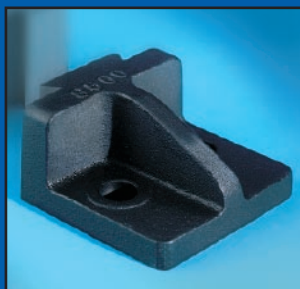

Bolt Down Adapter Series

Ideal for bench tops, mill tables or any suitable flat surface

(Accessory Model 8500-00A shown left, See selection chart below for your application)

Bolt Down Adapter Selection Chart

Accessory Model#	Fits Sky Hook Model#	Tool Holder Equivalent
8500-00A	8500-00	KDK 100, 150, 200, NIX
8500-02-AS	8500-02	CA Aloris, Dorian SD40CA, DTM TP100A, Phase II 400
8500-02A-AS	8500-02A	BXA Aloris, Dorian SD30BXA, DTM TP75A, Phase II 200
8500-03-AS	8500-03	CXA Aloris, Dorian SD35CXA, DTM TP90A, Phase II 300
8500-04-AS	8500-04	KDK 300
8500-05-AS	8500-05	DA Aloris, Dorian SD50DA



Individual Counterweight
Accessory Model CW1-8570

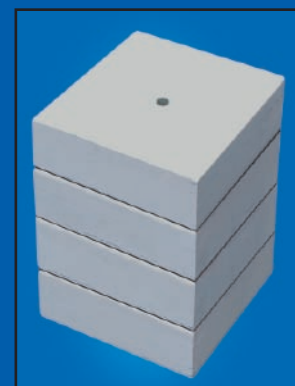

Complete Counterweight Kit
Accessory Model CW-8570



Vise Hook
Accessory Model 8515



Nylon Sling
Accessory Model 8510 Series
(Available in 3ft, 4ft, 5ft, 6ft lengths)



Chuck Hook
Accessory Model 8520



Choker Collar
Accessory Model 8507

industry leader since 1969

SKY HOOK

ACCESSORIES

Choker Collar

Accessory Model 8507

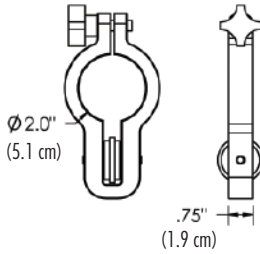

- Designed to slide down the boom for adjustable reach
- Allows for operation in tight working conditions
- Choker Collar is not adjustable under load
- For use with all Sky Hook models

Chuck Hook

Accessory Model 8520

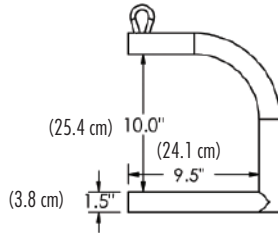

- Designed to safely & easily handle up to a 20" manual chuck
- Simply tighten the jaws on the Chuck Hook and lift
- Works with most manual style chucks
- Load limit 300 lbs. (136 kg)
- For use with all Sky Hook models

Vise Hook

Accessory Model 8515

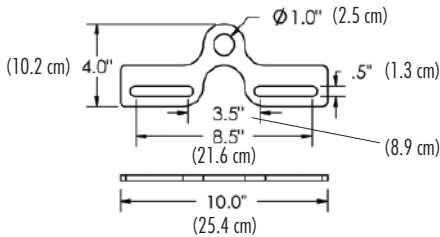

- Designed to safely and easily lift a 6-10" jaw vise
- Convenient method for attaching Sky Hook to vise
- Prevents back strain when changing setups
- For use with all Sky Hook models

Nylon Sling

Accessory Model 8510 Series

Rigging Configurations

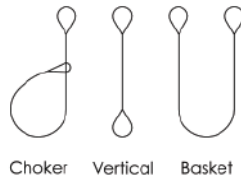

- Eye and eye style nylon sling ideal for irregular-shaped loads
- Perfect for choker, vertical or basket style rigging to meet a variety of applications
- Abrasion-resistant Cordura® nylon "armor jacket" protection for better wear resistance
- Narrow 1" width of sling works well with all Sky Hook models

Individual Counterweight

Accessory Model CW1-8570

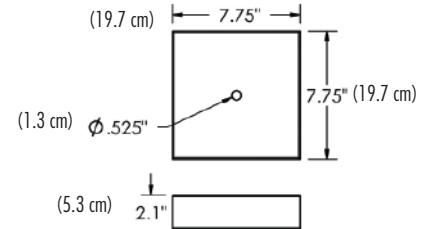

- Designed as a convenient and compact counterweight solution
- Counterweights are stackable and include center hole for securing to base
- For use with Sky Hook Model 8565 and Sky Hook Model 8570

(1) Painted Lead Ballast

Dimensions: 7-3/4" x 7-3/4" x 2-1/8"; approx. weight 50 lbs (22.7 kg) each ballast

Complete Counterweight Kit

Accessory Model CW-8570

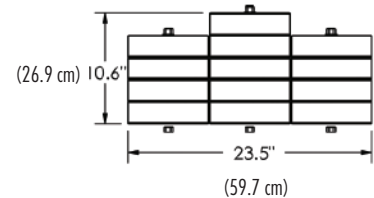

- Designed as a convenient and compact counterweight solution
- Counterweights are stackable and include center hole for securing to base
- For use with Sky Hook Model 8565 and Sky Hook Model 8570

Kit Includes:

(13) Painted Lead Ballasts

(Dimensions: 7-3/4" x 7-3/4" x 2-1/8"; approx. weight 50 lbs (22.7 kg) each ballast)

(1) Hardware Kit

(1) Instruction Sheet

Bolt Down Adapter Series:

- Ideal for bench tops, mill tables or any suitable flat surface
- Used with Model 8500 Series Sky Hook (see selection chart on reverse)

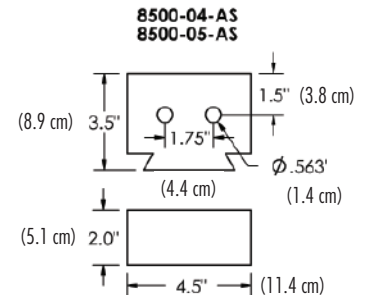
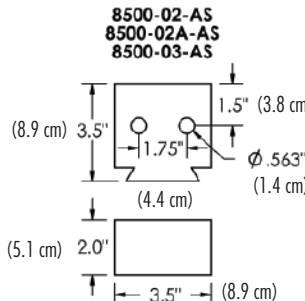
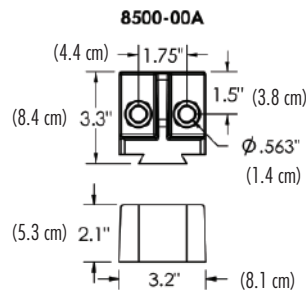

Attitude is Everything!

www.skyhookmfr.com

ATTCO, INC. DBA

SYCLONE ATTCO SERVICE

P.O. Box 458, Emmett, ID 83617

800-4SKYHOOK (800-475-9466)

Fax: 800-973-3355

E-mail: info@skyhookmfr.com