

PORTABLE LINE BORING
MACHINES

SC2 Compact

from \varnothing 62 mm to \varnothing 250 mm (2,44" - 9,84")



SC2 Compact



The **Supercombinata SC2 Compact**, thanks to its standard equipment, is suitable to perform internal **line boring** and internal **overlay welding** within a working range from **Ø 62 mm** to **Ø 250 mm** in very small spaces. By means of **extra kits** it is able to perform external line boring, facing of orthogonal planes and creation of circlips grooves. With additional **accessories**, the Supercombinata can be adapted to many different needs of our customers.

TECHNICAL SPECIFICATIONS

DIAMETERS

Boring bar diameter:	Ø 60 x 2200 mm
In line boring:	Ø 62 – 250 mm
External line boring:	Extra kit
Internal welding:	Ø 42 – 250 mm
Facing of orthogonal planes:	Extra kit

ROTATION MOTOR

AC motor:	Single phase
Power at rated speed:	1800 W
Output torque at the bar:	350 Nm with 100 rpm
1° speed:	max 100 rpm (170 Nm)
2° speed:	max 340 rpm (50 Nm)

FEED MOTOR

Gear motor:	DC
Power at rated speed:	45 W
Max Speed:	11 rpm
Feed system:	Electromechanical
Feed:	Manual/Automatic

WELDING TECHNOLOGY

Spiral:	Continuous with variable step
Welding machine:	Compatible with MIG/MAG wire with EURO connector

LONGITUDINAL STROKE

Unlimited:	With 250 mm pitch
------------	-------------------

ELECTRONIC CONTROL PANEL

Voltage:	220/240 V (50/60 Hz)
Main switch:	Available
Emergency switch:	Available
Inverter feed:	RH/LH
Inverter rotation:	CW/CCW
Speed regulator:	Rotation/Feed
Electrical absorption:	2000 W
Control panel 110/120 V:	Upon request

DIMENSIONS

Length:	545 mm
Width:	220 mm
Height:	380 mm
Weight central unit:	34 kg

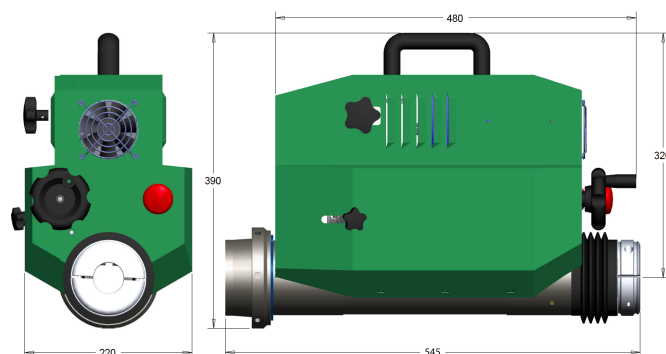

STANDARD EQUIPMENT

QTY 1	MAIN UNIT
QTY 1	BORING MACHINE STAND
QTY 1	ELECTRONICAL CONTROL PANEL
QTY 1	CONTROL PANEL HOLDER
QTY 1	CABLE CONTROL PANEL /MACHINE
QTY 1	POWER CABLE 220V
QTY 1	BORING BAR Ø 60X2200 MM
QTY 1	BORING BAR EXTENSION 415 MM
QTY 1	TOOL HOLDER FOR BORING D. 120-250 MM
QTY 1	BOX WITH 10 CUTTING INSERTS
QTY 2	MAIN BAR SUPPORT
QTY 2	ADDITIONAL SUPPORT
QTY 1	TELESCOPIC SHAFT FOR WELDING
QTY 1	REDUCTION BUSHING DRAWING TORCH
QTY 1	REDUCTION BUSHING LOCKING TORCH

QTY 1	TOOL HOLDER ADJUSTING BUSHING
QTY 5	DIFFUSOR EXTENSION 35 MM
QTY 4	SHORT GAS NOZZLE
QTY 4	LONG GAS NOZZLE
QTY 5	SHORT CONTACT TIP Ø 0.8 MM WIRE
QTY 5	LONG CONTACT TIP Ø 0.8 MM WIRE
QTY 1	O-RING FOR WELDING SHAFT 90X5 MM
QTY 1	TERMINAL LANCE FOR EXTERNAL WELDING
QTY 1	CENTRING SYSTEM FOR THROUGH HOLES
QTY 1	CENTRING SYSTEM FOR BLIND HOLES
QTY 1	TELESCOPIC GAUGE UP TO Ø 250 MM
QTY 1	DIAL GAUGE
QTY 1	DIAL GAUGE SUPPORT
QTY 1	SET OF WRENCHES
QTY 1	SCREWS AND BOLTS



• EXTRA KITS

BORING REDUCTION

KEP00594-C	Ø 22 - 44 mm (0,87" - 1,73")
KEP00593-C	Ø 32 - 70 mm (1,26" - 2,76")
KEP00688-C	Ø 42 - 160 mm (1,65" - 6,30")
KEP00687-C	for jobs with KES00186

FACING

KES00186*	Ø 48 - 255 mm (1,89" - 10,04")
-----------	--------------------------------

*SC2 / SC2 Compact/ SC3 compatible by using KEP00687

OD MACHING

KEL00202	Ø 100 - 200 mm - D. 200 mm (3,94" - 7,87")
KEL00203	Ø 150 - 300 mm - D. 300 mm (3,94" - 11,81")

• ACCESSORIES

AE030025	BORING BAR Ø 60X1100 MM
AE001027	BORING BAR Ø 60X1500 MM
AE003014	BORING BAR Ø 60X3000 MM
AE030026	TOOL HOLDER BAR Ø 60X2200 MM WITH DOUBLE TAPER
AE003015	TOOL HOLDER BAR Ø 60X3000 MM WITH DOUBLE TAPER
AE000443	MORSE TAPER ATTACHMENT 4 MM
AE000442	INTERNAL JOINT FOR BORING BAR Ø 60 MM
AE000441	EXTERNAL JOINT FOR BORING BAR Ø 60 MM
GC35SC	INTERNAL SUPPORT D. 200-300 MM
GC39SC	SET OF 2 CENTRING CONES D. 135-225 MM
SG00127	TERMINAL LANCE D. 30-50 MM
COT90201	LONG CONTACT TIP Ø 1,0 MM WIRE
COT90202	SHORT CONTACT TIP Ø 1,0 MM WIRE



Elsa Srl
Località La Petrizia SS 106
88050 Sellia Marina (CZ) - Italia
Tel: (+39) 0961 962854
Fax: (+39) 0961 968716
info@elsasrl.com

www.elsasrl.com

EN

SUPERCOMBINATA
SC2 COMPACT